

# SS平歯車 モジュール 1

平歯車  
SS

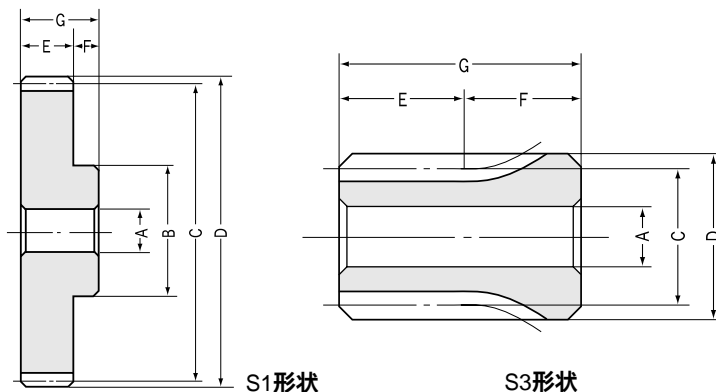

## モジュール 1

カタログ記号	モジュール	歯数	穴径	ボス径	基準円直径	歯先円直径	歯幅	ボス長さ	全長	ウェブ厚	リム径
	<i>m</i>	<i>z</i>	AH7	B	C	D	E	F	G	H	I
SS1- 15	1	15	8	17	15	17	10	20	30		
SS1- 16	1	16	8	18	16	18	10	20	30		
SS1- 17	1	17	8	19	17	19	10	20	30		
SS1- 18	1	18	8	20	18	20	10	20	30		
SS1- 19	1	19	8	21	19	21	10	20	30		
SS1- 20	1	20	8	16	20	22	10	10	20		
SS1- 21	1	21	8	17	21	23	10	10	20		
SS1- 22	1	22	8	18	22	24	10	10	20		
SS1- 23	1	23	8	18	23	25	10	10	20		
SS1- 24	1	24	8	20	24	26	10	10	20		
SS1- 25	1	25	8	20	25	27	10	10	20		
SS1- 26	1	26	8	22	26	28	10	10	20		
SS1- 27	1	27	8	22	27	29	10	10	20		
SS1- 28	1	28	8	22	28	30	10	10	20		
SS1- 29	1	29	8	24	29	31	10	10	20		
SS1- 30	1	30	10	25	30	32	10	10	20		
SS1- 32	1	32	10	26	32	34	10	10	20		
SS1- 34	1	34	10	26	34	36	10	10	20		
SS1- 35	1	35	10	26	35	37	10	10	20		
SS1- 36	1	36	10	28	36	38	10	10	20		
SS1- 38	1	38	10	32	38	40	10	10	20		
SS1- 40	1	40	10	35	40	42	10	10	20		
SS1- 42	1	42	10	35	42	44	10	10	20		
SS1- 44	1	44	10	35	44	46	10	10	20		
SS1- 45	1	45	10	35	45	47	10	10	20		
SS1- 46	1	46	10	35	46	48	10	10	20		
SS1- 48	1	48	10	35	48	50	10	10	20		
SS1- 50	1	50	10	35	50	52	10	10	20		
SS1- 52	1	52	10	35	52	54	10	10	20		
SS1- 54	1	54	10	35	54	56	10	10	20		
SS1- 55	1	55	10	35	55	57	10	10	20		
SS1- 56	1	56	10	35	56	58	10	10	20		
SS1- 58	1	58	10	35	58	60	10	10	20		
SS1- 60	1	60	10	35	60	62	10	10	20		
SS1- 62	1	62	10	40	62	64	10	10	20		
SS1- 64	1	64	10	40	64	66	10	10	20		
SS1- 65	1	65	10	40	65	67	10	10	20		
SS1- 66	1	66	10	40	66	68	10	10	20		
SS1- 68	1	68	10	40	68	70	10	10	20		
SS1- 70	1	70	10	40	70	72	10	10	20		
SS1- 72	1	72	10	40	72	74	10	10	20		
SS1- 75	1	75	10	40	75	77	10	10	20		
SS1- 76	1	76	10	40	76	78	10	10	20		
SS1- 80	1	80	10	40	80	82	10	10	20		
SS1- 84	1	84	10	40	84	86	10	10	20		
SS1- 85	1	85	10	40	85	87	10	10	20		
SS1- 88	1	88	10	40	88	90	10	10	20		
SS1- 90	1	90	10	40	90	92	10	10	20		
SS1- 95	1	95	10	40	95	97	10	10	20		
SS1- 96	1	96	10	40	96	98	10	10	20		
SS1-100	1	100	10	40	100	102	10	10	20		
SS1-110	1	110	15	50	110	112	10	10	20		
SS1-120	1	120	15	50	120	122	10	10	20		
SS1-150	1	150	20	120	150	152	10	10	20		
SS1-200	1	200	20	160	200	202	10	10	20		



## 共通仕様

精度等級	JIS N8級 (JIS B 1702-1:1998) 旧JIS 4級 (JIS B 1702:1976)	歯面硬度	194HB以下
歯形	並歯	表面処理	黒染
圧力角	20°	歯面仕上げ	切削
材 料	S45C	歯切基準面	穴
熱 処 理		追加工	可能

形状	許容トルク(N・m)注1		許容トルク(kgf・m)		バックラッシュ (mm) 注2	質量 (kg)	価格 (円)	カタログ記号
	曲げ強さ	歯面強さ	曲げ強さ	歯面強さ				
S3	3.694	0.1746	(0.3767)	(0.0178)	0.08 ~ 0.18	0.03	410	<b>SS1- 15</b>
S3	4.093	0.201	(0.4174)	(0.0205)	0.08 ~ 0.18	0.04	420	<b>SS1- 16</b>
S3	4.498	0.2295	(0.4587)	(0.0234)	0.08 ~ 0.18	0.05	440	<b>SS1- 17</b>
S3	4.909	0.2599	(0.5006)	(0.0265)	0.08 ~ 0.18	0.05	450	<b>SS1- 18</b>
S3	5.326	0.2922	(0.5431)	(0.0298)	0.08 ~ 0.18	0.06	460	<b>SS1- 19</b>
S1	5.747	0.3275	(0.586)	(0.0334)	0.08 ~ 0.18	0.03	470	<b>SS1- 20</b>
S1	6.171	0.3638	(0.6293)	(0.0371)	0.1 ~ 0.22	0.03	480	<b>SS1- 21</b>
S1	6.601	0.403	(0.6731)	(0.0411)	0.1 ~ 0.22	0.04	490	<b>SS1- 22</b>
S1	7.033	0.4452	(0.7172)	(0.0454)	0.1 ~ 0.22	0.04	490	<b>SS1- 23</b>
S1	7.469	0.4903	(0.7616)	(0.05)	0.1 ~ 0.22	0.05	500	<b>SS1- 24</b>
S1	7.908	0.5364	(0.8064)	(0.0547)	0.1 ~ 0.22	0.05	500	<b>SS1- 25</b>
S1	8.349	0.5825	(0.8514)	(0.0594)	0.1 ~ 0.22	0.06	530	<b>SS1- 26</b>
S1	8.794	0.6315	(0.8967)	(0.0644)	0.1 ~ 0.22	0.06	530	<b>SS1- 27</b>
S1	9.241	0.6816	(0.9423)	(0.0695)	0.1 ~ 0.22	0.07	540	<b>SS1- 28</b>
S1	9.69	0.7345	(0.9881)	(0.0749)	0.1 ~ 0.22	0.08	550	<b>SS1- 29</b>
S1	10.14	0.7894	(1.034)	(0.0805)	0.1 ~ 0.22	0.08	560	<b>SS1- 30</b>
S1	11.05	0.9042	(1.127)	(0.0922)	0.1 ~ 0.22	0.1	580	<b>SS1- 32</b>
S1	11.96	1.028	(1.22)	(0.1048)	0.1 ~ 0.22	0.11	620	<b>SS1- 34</b>
S1	12.42	1.092	(1.267)	(0.1114)	0.1 ~ 0.22	0.11	630	<b>SS1- 35</b>
S1	12.89	1.16	(1.314)	(0.1183)	0.1 ~ 0.22	0.12	650	<b>SS1- 36</b>
S1	13.81	1.3	(1.408)	(0.1326)	0.1 ~ 0.22	0.14	710	<b>SS1- 38</b>
S1	14.74	1.449	(1.503)	(0.1478)	0.1 ~ 0.22	0.16	730	<b>SS1- 40</b>
S1	15.67	1.606	(1.598)	(0.1638)	0.12 ~ 0.26	0.17	760	<b>SS1- 42</b>
S1	16.61	1.772	(1.694)	(0.1807)	0.12 ~ 0.26	0.18	820	<b>SS1- 44</b>
S1	17.08	1.857	(1.742)	(0.1894)	0.12 ~ 0.26	0.18	830	<b>SS1- 45</b>
S1	17.55	1.946	(1.79)	(0.1984)	0.12 ~ 0.26	0.19	850	<b>SS1- 46</b>
S1	18.5	2.128	(1.887)	(0.217)	0.12 ~ 0.26	0.2	910	<b>SS1- 48</b>
S1	19.45	2.319	(1.983)	(0.2365)	0.12 ~ 0.26	0.22	930	<b>SS1- 50</b>
S1	20.4	2.518	(2.08)	(0.2568)	0.12 ~ 0.26	0.23	950	<b>SS1- 52</b>
S1	21.36	2.726	(2.178)	(0.278)	0.12 ~ 0.26	0.24	1,010	<b>SS1- 54</b>
S1	21.83	2.833	(2.226)	(0.2889)	0.12 ~ 0.26	0.25	1,030	<b>SS1- 55</b>
S1	22.31	2.942	(2.275)	(0.3)	0.12 ~ 0.26	0.26	1,040	<b>SS1- 56</b>
S1	23.27	3.167	(2.373)	(0.3229)	0.12 ~ 0.26	0.27	1,140	<b>SS1- 58</b>
S1	24.22	3.4	(2.47)	(0.3467)	0.12 ~ 0.26	0.28	1,150	<b>SS1- 60</b>
S1	25.18	3.642	(2.568)	(0.3714)	0.12 ~ 0.26	0.3	1,250	<b>SS1- 62</b>
S1	26.15	3.892	(2.667)	(0.3969)	0.12 ~ 0.26	0.34	1,270	<b>SS1- 64</b>
S1	26.63	4.021	(2.716)	(0.41)	0.12 ~ 0.26	0.35	1,280	<b>SS1- 65</b>
S1	27.12	4.151	(2.765)	(0.4233)	0.12 ~ 0.26	0.36	1,290	<b>SS1- 66</b>
S1	28.08	4.419	(2.863)	(0.4506)	0.12 ~ 0.26	0.38	1,390	<b>SS1- 68</b>
S1	29.05	4.695	(2.962)	(0.4788)	0.12 ~ 0.26	0.4	1,410	<b>SS1- 70</b>
S1	30.02	4.982	(3.061)	(0.508)	0.12 ~ 0.26	0.41	1,520	<b>SS1- 72</b>
S1	31.47	5.431	(3.209)	(0.5538)	0.12 ~ 0.26	0.43	1,550	<b>SS1- 75</b>
S1	31.95	5.586	(3.258)	(0.5696)	0.12 ~ 0.26	0.45	1,600	<b>SS1- 76</b>
S1	33.9	6.226	(3.457)	(0.6349)	0.12 ~ 0.26	0.49	1,690	<b>SS1- 80</b>
S1	35.84	6.902	(3.655)	(0.7038)	0.16 ~ 0.32	0.53	1,830	<b>SS1- 84</b>
S1	36.33	7.076	(3.705)	(0.7216)	0.16 ~ 0.32	0.55	1,840	<b>SS1- 85</b>
S1	37.79	7.615	(3.854)	(0.7765)	0.16 ~ 0.32	0.57	1,930	<b>SS1- 88</b>
S1	38.77	7.984	(3.953)	(0.8142)	0.16 ~ 0.32	0.59	1,930	<b>SS1- 90</b>
S1	41.21	8.948	(4.202)	(0.9125)	0.16 ~ 0.32	0.66	2,090	<b>SS1- 95</b>
S1	41.7	9.148	(4.252)	(0.9328)	0.16 ~ 0.32	0.67	2,100	<b>SS1- 96</b>
S1	43.66	9.973	(4.452)	(1.017)	0.16 ~ 0.32	0.7	2,310	<b>SS1-100</b>
S1	48.56	12.18	(4.952)	(1.242)	0.16 ~ 0.32	0.87	2,470	<b>SS1-110</b>
S1	53.47	14.66	(5.452)	(1.495)	0.16 ~ 0.32	1	2,810	<b>SS1-120</b>
S1	68.24	23.64	(6.959)	(2.411)	0.16 ~ 0.32	2.23	4,030	<b>SS1-150</b>
S1	71.5	33.58	(7.291)	(3.424)	0.2 ~ 0.4	4	6,370	<b>SS1-200</b>

【注1】表記の許容トルクは任意の使用条件で計算した参考値です。詳細については27頁をご参照ください。

【注2】バックラッシュは同一型番どうし理論値で組立てたときの数値です。

# SS平歯車 モジュール 1.5

平歯車  
SS

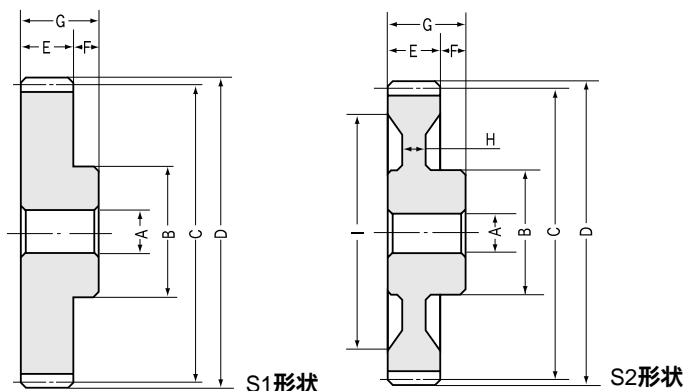

## モジュール 1.5

カタログ記号	モジュール	歯数	穴径	ボス径	基準円直径	歯先円直径	歯幅	ボス長さ	全長	ウェブ厚	リム径
	<i>m</i>	<i>z</i>	AH7	B	C	D	E	F	G	H	I
SS1.5-12	1.5	12	8	21	18	21	15	15	30		
SS1.5-13	1.5	13	8	22.5	19.5	22.5	15	15	30		
SS1.5-14	1.5	14	8	16	21	24	15	10	25		
SS1.5-15	1.5	15	8	18	22.5	25.5	15	10	25		
SS1.5-16	1.5	16	8	20	24	27	15	10	25		
SS1.5-17	1.5	17	8	21	25.5	28.5	15	10	25		
SS1.5-18	1.5	18	8	22	27	30	15	10	25		
SS1.5-19	1.5	19	8	23	28.5	31.5	15	10	25		
SS1.5-20	1.5	20	8	24	30	33	15	10	25		
SS1.5-21	1.5	21	8	25	31.5	34.5	15	10	25		
SS1.5-22	1.5	22	8	26	33	36	15	10	25		
SS1.5-23	1.5	23	8	27	34.5	37.5	15	10	25		
SS1.5-24	1.5	24	8	28	36	39	15	10	25		
SS1.5-25	1.5	25	8	30	37.5	40.5	15	10	25		
SS1.5-26	1.5	26	10	32	39	42	15	10	25		
SS1.5-27	1.5	27	10	34	40.5	43.5	15	10	25		
SS1.5-28	1.5	28	10	36	42	45	15	10	25		
SS1.5-29	1.5	29	10	37	43.5	46.5	15	10	25		
SS1.5-30	1.5	30	10	38	45	48	15	10	25		
SS1.5-32	1.5	32	10	40	48	51	15	10	25		
SS1.5-34	1.5	34	10	40	51	54	15	10	25		
SS1.5-35	1.5	35	10	42	52.5	55.5	15	10	25		
SS1.5-36	1.5	36	10	45	54	57	15	10	25		
SS1.5-38	1.5	38	12	45	57	60	15	10	25		
SS1.5-40	1.5	40	12	45	60	63	15	10	25		
SS1.5-42	1.5	42	12	45	63	66	15	10	25		
SS1.5-44	1.5	44	12	45	66	69	15	10	25		
SS1.5-45	1.5	45	12	45	67.5	70.5	15	10	25		
SS1.5-46	1.5	46	12	45	69	72	15	10	25		
SS1.5-48	1.5	48	12	45	72	75	15	10	25		
SS1.5-50	1.5	50	12	45	75	78	15	10	25		
SS1.5-52	1.5	52	15	50	78	81	15	10	25		
SS1.5-54	1.5	54	15	50	81	84	15	10	25		
SS1.5-55	1.5	55	15	50	82.5	85.5	15	10	25		
SS1.5-56	1.5	56	15	50	84	87	15	10	25		
SS1.5-58	1.5	58	15	50	87	90	15	10	25		
SS1.5-60	1.5	60	15	50	90	93	15	10	25		
SS1.5-62	1.5	62	15	55	93	96	15	10	25		
SS1.5-64	1.5	64	15	55	96	99	15	10	25		
SS1.5-65	1.5	65	15	55	97.5	100.5	15	10	25		
SS1.5-66	1.5	66	15	55	99	102	15	10	25		
SS1.5-68	1.5	68	15	55	102	105	15	10	25		
SS1.5-70	1.5	70	15	55	105	108	15	10	25		
SS1.5-72	1.5	72	15	55	108	111	15	10	25		
SS1.5-75	1.5	75	15	60	112.5	115.5	15	10	25		
SS1.5-76	1.5	76	15	60	114	117	15	10	25		
SS1.5-80	1.5	80	15	60	120	123	15	10	25		
SS1.5-84	1.5	84	15	60	126	129	15	10	25		
SS1.5-85	1.5	85	15	60	127.5	130.5	15	10	25		
SS1.5-88	1.5	88	15	60	132	135	15	10	25		
SS1.5-90	1.5	90	15	60	135	138	15	10	25		
SS1.5-95	1.5	95	15	60	142.5	145.5	15	10	25		
SS1.5-100	1.5	100	15	60	150	153	15	10	25	9	133
SS1.5-120	1.5	120	15	70	180	183	15	10	25	10	153
SS1.5-150	1.5	150	20	180	225	228	15	10	25		
SS1.5-200	1.5	200	25	240	300	303	15	10	25		

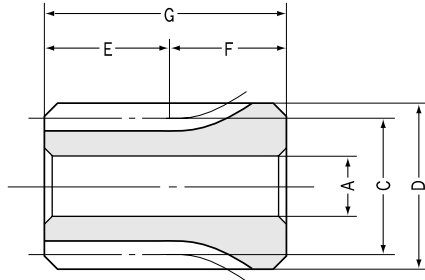

S3形状

## 共通仕様

精度等級	JIS N8級 (JIS B 1702-1:1998) 旧JIS 4級 (JIS B 1702:1976)	歯面硬度	194HB以下
歯形	並歯	表面処理	黒染
圧力角	20°	歯面仕上げ	切削
材料	S45C	歯切基準面	穴
熱処理		追加工	可能

形状	許容トルク(N・m) 注1		許容トルク(kgf・m)		バックラッシュ (mm) 注2	質量 (kg)	価格 (円)	カタログ記号
	曲げ強さ	歯面強さ	曲げ強さ	歯面強さ				
S3	8.59	0.3628	(0.8759)	(0.037)	0.1 ~ 0.22	0.05	470	<b>SS1.5-12</b>
S3	9.856	0.4374	(1.005)	(0.0446)	0.1 ~ 0.22	0.07	480	<b>SS1.5-13</b>
S1	11.15	0.5158	(1.137)	(0.0526)	0.1 ~ 0.22	0.06	490	<b>SS1.5-14</b>
S1	12.47	0.6031	(1.272)	(0.0615)	0.1 ~ 0.22	0.06	500	<b>SS1.5-15</b>
S1	13.82	0.6982	(1.409)	(0.0712)	0.1 ~ 0.22	0.07	530	<b>SS1.5-16</b>
S1	15.18	0.8012	(1.548)	(0.0817)	0.1 ~ 0.22	0.09	550	<b>SS1.5-17</b>
S1	16.57	0.912	(1.69)	(0.093)	0.1 ~ 0.22	0.09	590	<b>SS1.5-18</b>
S1	17.98	1.03	(1.833)	(0.105)	0.1 ~ 0.22	0.11	600	<b>SS1.5-19</b>
S1	19.4	1.154	(1.978)	(0.1177)	0.1 ~ 0.22	0.12	610	<b>SS1.5-20</b>
S1	20.83	1.288	(2.124)	(0.1313)	0.12 ~ 0.26	0.13	620	<b>SS1.5-21</b>
S1	22.28	1.428	(2.272)	(0.1456)	0.12 ~ 0.26	0.15	660	<b>SS1.5-22</b>
S1	23.74	1.576	(2.421)	(0.1607)	0.12 ~ 0.26	0.18	710	<b>SS1.5-23</b>
S1	25.21	1.732	(2.571)	(0.1766)	0.12 ~ 0.26	0.19	740	<b>SS1.5-24</b>
S1	26.69	1.897	(2.722)	(0.1934)	0.12 ~ 0.26	0.2	790	<b>SS1.5-25</b>
S1	28.18	2.06	(2.874)	(0.2101)	0.12 ~ 0.26	0.21	800	<b>SS1.5-26</b>
S1	29.67	2.231	(3.026)	(0.2275)	0.12 ~ 0.26	0.23	830	<b>SS1.5-27</b>
S1	31.18	2.409	(3.18)	(0.2457)	0.12 ~ 0.26	0.24	850	<b>SS1.5-28</b>
S1	32.7	2.595	(3.335)	(0.2646)	0.12 ~ 0.26	0.25	860	<b>SS1.5-29</b>
S1	34.22	2.787	(3.49)	(0.2842)	0.12 ~ 0.26	0.26	890	<b>SS1.5-30</b>
S1	37.28	3.192	(3.802)	(0.3255)	0.12 ~ 0.26	0.3	950	<b>SS1.5-32</b>
S1	40.37	3.626	(4.117)	(0.3698)	0.12 ~ 0.26	0.33	990	<b>SS1.5-34</b>
S1	41.92	3.854	(4.275)	(0.393)	0.12 ~ 0.26	0.34	1,050	<b>SS1.5-35</b>
S1	43.48	4.089	(4.434)	(0.417)	0.12 ~ 0.26	0.39	1,070	<b>SS1.5-36</b>
S1	46.61	4.581	(4.753)	(0.4671)	0.12 ~ 0.26	0.43	1,190	<b>SS1.5-38</b>
S1	49.75	5.1	(5.073)	(0.5201)	0.12 ~ 0.26	0.44	1,190	<b>SS1.5-40</b>
S1	52.91	5.65	(5.395)	(0.5761)	0.14 ~ 0.32	0.47	1,320	<b>SS1.5-42</b>
S1	56.07	6.227	(5.718)	(0.635)	0.14 ~ 0.32	0.51	1,430	<b>SS1.5-44</b>
S1	57.66	6.527	(5.88)	(0.6656)	0.14 ~ 0.32	0.52	1,440	<b>SS1.5-45</b>
S1	59.25	6.834	(6.042)	(0.6969)	0.14 ~ 0.32	0.57	1,480	<b>SS1.5-46</b>
S1	62.44	7.473	(6.367)	(0.762)	0.14 ~ 0.32	0.58	1,580	<b>SS1.5-48</b>
S1	65.65	8.147	(6.694)	(0.8308)	0.14 ~ 0.32	0.62	1,610	<b>SS1.5-50</b>
S1	68.85	8.852	(7.021)	(0.9027)	0.14 ~ 0.32	0.7	1,710	<b>SS1.5-52</b>
S1	72.07	9.588	(7.349)	(0.9777)	0.14 ~ 0.32	0.74	1,850	<b>SS1.5-54</b>
S1	73.68	9.963	(7.513)	(1.016)	0.14 ~ 0.32	0.75	1,850	<b>SS1.5-55</b>
S1	75.29	10.36	(7.678)	(1.056)	0.14 ~ 0.32	0.77	1,860	<b>SS1.5-56</b>
S1	78.52	11.15	(8.007)	(1.137)	0.14 ~ 0.32	0.86	1,990	<b>SS1.5-58</b>
S1	81.77	11.97	(8.338)	(1.221)	0.14 ~ 0.32	0.87	2,020	<b>SS1.5-60</b>
S1	85	12.84	(8.668)	(1.309)	0.14 ~ 0.32	0.99	2,180	<b>SS1.5-62</b>
S1	88.26	13.72	(9)	(1.399)	0.14 ~ 0.32	1	2,420	<b>SS1.5-64</b>
S1	89.89	14.18	(9.166)	(1.446)	0.14 ~ 0.32	1	2,430	<b>SS1.5-65</b>
S1	91.51	14.64	(9.332)	(1.493)	0.14 ~ 0.32	1.1	2,490	<b>SS1.5-66</b>
S1	94.77	15.59	(9.664)	(1.59)	0.14 ~ 0.32	1.1	2,510	<b>SS1.5-68</b>
S1	98.04	16.57	(9.997)	(1.69)	0.14 ~ 0.32	1.2	2,520	<b>SS1.5-70</b>
S1	101.3	17.58	(10.33)	(1.793)	0.14 ~ 0.32	1.2	2,730	<b>SS1.5-72</b>
S1	106.2	19.15	(10.83)	(1.953)	0.14 ~ 0.32	1.4	2,810	<b>SS1.5-75</b>
S1	107.9	19.7	(11)	(2.009)	0.14 ~ 0.32	1.5	2,840	<b>SS1.5-76</b>
S1	114.4	22	(11.67)	(2.243)	0.14 ~ 0.32	1.5	3,090	<b>SS1.5-80</b>
S1	121	24.43	(12.34)	(2.491)	0.18 ~ 0.38	1.7	3,350	<b>SS1.5-84</b>
S1	122.6	25.06	(12.5)	(2.555)	0.18 ~ 0.38	1.7	3,420	<b>SS1.5-85</b>
S1	127.6	26.99	(13.01)	(2.752)	0.18 ~ 0.38	1.9	3,460	<b>SS1.5-88</b>
S1	130.8	28.31	(13.34)	(2.887)	0.18 ~ 0.38	1.9	3,810	<b>SS1.5-90</b>
S1	139.1	31.78	(14.18)	(3.241)	0.18 ~ 0.38	2.1	3,920	<b>SS1.5-95</b>
S2	147.4	35.46	(15.03)	(3.616)	0.18 ~ 0.38	1.8	4,370	<b>SS1.5-100</b>
S2	180.4	52.28	(18.4)	(5.331)	0.18 ~ 0.38	2.8	6,040	<b>SS1.5-120</b>
S1	191.9	70.31	(19.57)	(7.17)	0.18 ~ 0.38	6.62	8,460	<b>SS1.5-150</b>
S1	261.4	130.5	(26.66)	(13.31)	0.22 ~ 0.46	11.8	13,990	<b>SS1.5-200</b>

【注1】表記の許容トルクは任意の使用条件で計算した参考値です。詳細については27頁をご参照ください。

【注2】バックラッシュは同一型番どうし理論値で組立てたときの数値です。

# SS平歯車 モジュール2

平歯車  
SS

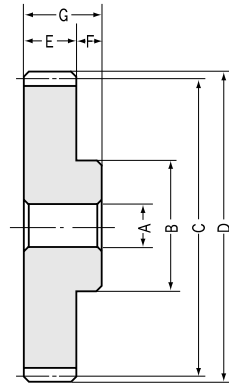
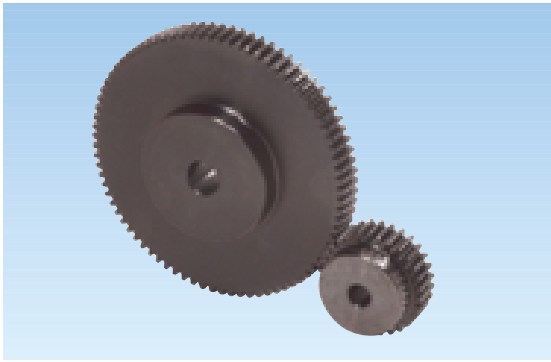

S1形状

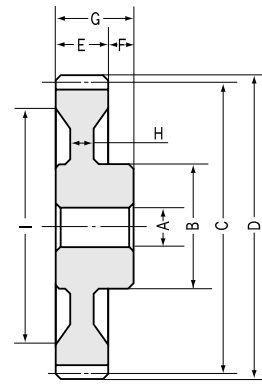

S2形状

## モジュール 2

カタログ記号	モジュール	歯数	穴径	ボス径	基準円直径	歯先円直径	歯幅	ボス長さ	全長	ウェブ厚	リム径
	m	z	AH7	B	C	D	E	F	G	H	I
SS2-12	2	12	10	18	24	28	20	10	30		
SS2-13	2	13	10	20	26	30	20	10	30		
SS2-14	2	14	10	20	28	32	20	10	30		
SS2-15	2	15	12	24	30	34	20	10	30		
SS2-16	2	16	12	26	32	36	20	10	30		
SS2-17	2	17	12	28	34	38	20	10	30		
SS2-18	2	18	12	30	36	40	20	10	30		
SS2-19	2	19	12	31	38	42	20	10	30		
SS2-20	2	20	12	32	40	44	20	10	30		
SS2-21	2	21	12	34	42	46	20	10	30		
SS2-22	2	22	12	36	44	48	20	10	30		
SS2-23	2	23	12	37	46	50	20	10	30		
SS2-24	2	24	12	38	48	52	20	10	30		
SS2-25	2	25	12	40	50	54	20	10	30		
SS2-26	2	26	12	42	52	56	20	10	30		
SS2-27	2	27	12	45	54	58	20	10	30		
SS2-28	2	28	12	45	56	60	20	10	30		
SS2-29	2	29	12	47	58	62	20	10	30		
SS2-30	2	30	12	50	60	64	20	10	30		
SS2-32	2	32	12	50	64	68	20	10	30		
SS2-34	2	34	12	50	68	72	20	10	30		
SS2-35	2	35	12	52	70	74	20	10	30		
SS2-36	2	36	12	55	72	76	20	10	30		
SS2-38	2	38	12	55	76	80	20	10	30		
SS2-40	2	40	15	55	80	84	20	10	30		
SS2-42	2	42	15	55	84	88	20	10	30		
SS2-44	2	44	15	55	88	92	20	10	30		
SS2-45	2	45	15	55	90	94	20	10	30		
SS2-46	2	46	15	55	92	96	20	10	30		
SS2-48	2	48	15	55	96	100	20	10	30		
SS2-50	2	50	15	55	100	104	20	10	30		
SS2-52	2	52	15	55	104	108	20	10	30		
SS2-54	2	54	15	55	108	112	20	10	30		
SS2-55	2	55	15	55	110	114	20	10	30		
SS2-56	2	56	15	55	112	116	20	10	30		
SS2-58	2	58	15	60	116	120	20	10	30		
SS2-60	2	60	15	60	120	124	20	10	30		
SS2-62	2	62	15	60	124	128	20	10	30		
SS2-64	2	64	15	60	128	132	20	10	30		
SS2-65	2	65	15	60	130	134	20	10	30		
SS2-66	2	66	15	60	132	136	20	10	30		
SS2-68	2	68	15	60	136	140	20	10	30		
SS2-70	2	70	15	60	140	144	20	10	30		
SS2-72	2	72	15	60	144	148	20	10	30		
SS2-75	2	75	20	60	150	154	20	10	30		
SS2-76	2	76	20	60	152	156	20	10	30		
SS2-80	2	80	20	60	160	164	20	10	30	12	136
SS2-84	2	84	20	70	168	172	20	10	30	12	140
SS2-85	2	85	20	70	170	174	20	10	30	12	146
SS2-88	2	88	20	70	176	180	20	10	30	12	150
SS2-90	2	90	20	70	180	184	20	10	30	12	156
SS2-95	2	95	20	70	190	194	20	10	30	12	166
SS2-100	2	100	20	70	200	204	20	10	30	12	176
SS2-120	2	120	20	90	240	244	20	10	30	12	210
SS2-150	2	150	25	240	300	304	20	10	30		



## 共通仕様

精度等級	JIS N8級 (JIS B 1702-1:1998) 旧JIS 4級 (JIS B 1702:1976)	歯面硬度	194HB以下
歯形	並歯	表面処理	黒染
圧力角	20°	歯面仕上げ	切削
材料	S45C	歯切基準面	穴
熱処理		追加工	可能

形状	許容トルク(N・m) 注1		許容トルク(kgf・m)		バックラッシ (mm) 注2	質量 (kg)	価格 (円)	カタログ記号
	曲げ強さ	歯面強さ	曲げ強さ	歯面強さ				
S1	20.36	0.8816	( 2.076 )	( 0.0899 )	0.12 ~ 0.26	0.09	590	<b>SS2- 12</b>
S1	23.36	1.067	( 2.382 )	( 0.1088 )	0.12 ~ 0.26	0.1	630	<b>SS2- 13</b>
S1	26.42	1.264	( 2.694 )	( 0.1289 )	0.12 ~ 0.26	0.1	670	<b>SS2- 14</b>
S1	29.56	1.479	( 3.014 )	( 0.1508 )	0.12 ~ 0.26	0.11	690	<b>SS2- 15</b>
S1	32.74	1.712	( 3.339 )	( 0.1746 )	0.12 ~ 0.26	0.15	730	<b>SS2- 16</b>
S1	35.99	1.962	( 3.67 )	( 0.2001 )	0.12 ~ 0.26	0.18	750	<b>SS2- 17</b>
S1	39.28	2.233	( 4.005 )	( 0.2277 )	0.12 ~ 0.26	0.2	830	<b>SS2- 18</b>
S1	42.61	2.521	( 4.345 )	( 0.2571 )	0.12 ~ 0.26	0.22	860	<b>SS2- 19</b>
S1	45.97	2.827	( 4.688 )	( 0.2883 )	0.12 ~ 0.26	0.22	890	<b>SS2- 20</b>
S1	49.38	3.153	( 5.035 )	( 0.3215 )	0.14 ~ 0.3	0.28	950	<b>SS2- 21</b>
S1	52.81	3.496	( 5.385 )	( 0.3565 )	0.14 ~ 0.3	0.3	980	<b>SS2- 22</b>
S1	56.27	3.858	( 5.738 )	( 0.3934 )	0.14 ~ 0.3	0.32	1,070	<b>SS2- 23</b>
S1	59.75	4.238	( 6.093 )	( 0.4322 )	0.14 ~ 0.3	0.35	1,090	<b>SS2- 24</b>
S1	63.26	4.638	( 6.451 )	( 0.4729 )	0.14 ~ 0.3	0.4	1,100	<b>SS2- 25</b>
S1	66.8	5.037	( 6.812 )	( 0.5136 )	0.14 ~ 0.3	0.42	1,180	<b>SS2- 26</b>
S1	70.35	5.452	( 7.174 )	( 0.556 )	0.14 ~ 0.3	0.47	1,200	<b>SS2- 27</b>
S1	73.92	5.885	( 7.538 )	( 0.6001 )	0.14 ~ 0.3	0.5	1,300	<b>SS2- 28</b>
S1	77.52	6.334	( 7.905 )	( 0.6459 )	0.14 ~ 0.3	0.58	1,310	<b>SS2- 29</b>
S1	81.12	6.801	( 8.272 )	( 0.6935 )	0.14 ~ 0.3	0.58	1,430	<b>SS2- 30</b>
S1	88.39	7.784	( 9.013 )	( 0.7938 )	0.14 ~ 0.3	0.64	1,460	<b>SS2- 32</b>
S1	95.7	8.838	( 9.759 )	( 0.9012 )	0.14 ~ 0.3	0.74	1,600	<b>SS2- 34</b>
S1	99.34	9.39	( 10.13 )	( 0.9575 )	0.14 ~ 0.3	0.75	1,710	<b>SS2- 35</b>
S1	103.1	9.963	( 10.51 )	( 1.016 )	0.14 ~ 0.3	0.8	1,730	<b>SS2- 36</b>
S1	110.5	11.17	( 11.27 )	( 1.139 )	0.14 ~ 0.3	0.9	1,870	<b>SS2- 38</b>
S1	117.9	12.45	( 12.02 )	( 1.27 )	0.14 ~ 0.3	0.93	1,990	<b>SS2- 40</b>
S1	125.4	13.81	( 12.79 )	( 1.408 )	0.18 ~ 0.36	1	2,050	<b>SS2- 42</b>
S1	132.9	15.23	( 13.55 )	( 1.553 )	0.18 ~ 0.36	1.1	2,210	<b>SS2- 44</b>
S1	136.7	15.97	( 13.94 )	( 1.628 )	0.18 ~ 0.36	1.1	2,300	<b>SS2- 45</b>
S1	140.4	16.73	( 14.32 )	( 1.706 )	0.18 ~ 0.36	1.2	2,350	<b>SS2- 46</b>
S1	148	18.3	( 15.09 )	( 1.866 )	0.18 ~ 0.36	1.3	2,600	<b>SS2- 48</b>
S1	155.6	19.94	( 15.87 )	( 2.033 )	0.18 ~ 0.36	1.4	2,730	<b>SS2- 50</b>
S1	163.2	21.65	( 16.64 )	( 2.208 )	0.18 ~ 0.36	1.5	2,820	<b>SS2- 52</b>
S1	170.8	23.44	( 17.42 )	( 2.39 )	0.18 ~ 0.36	1.6	2,940	<b>SS2- 54</b>
S1	174.7	24.36	( 17.81 )	( 2.484 )	0.18 ~ 0.36	1.6	2,950	<b>SS2- 55</b>
S1	178.5	25.3	( 18.2 )	( 2.58 )	0.18 ~ 0.36	1.7	3,020	<b>SS2- 56</b>
S1	186.1	27.27	( 18.98 )	( 2.781 )	0.18 ~ 0.36	1.8	3,550	<b>SS2- 58</b>
S1	193.8	29.33	( 19.76 )	( 2.991 )	0.18 ~ 0.36	1.9	3,590	<b>SS2- 60</b>
S1	201.5	31.47	( 20.55 )	( 3.209 )	0.18 ~ 0.36	2	3,640	<b>SS2- 62</b>
S1	209.2	33.69	( 21.33 )	( 3.435 )	0.18 ~ 0.36	2.1	3,710	<b>SS2- 64</b>
S1	213.1	34.82	( 21.73 )	( 3.551 )	0.18 ~ 0.36	2.3	3,750	<b>SS2- 65</b>
S1	216.9	35.98	( 22.12 )	( 3.669 )	0.18 ~ 0.36	2.4	3,770	<b>SS2- 66</b>
S1	224.7	38.35	( 22.91 )	( 3.911 )	0.18 ~ 0.36	2.6	4,140	<b>SS2- 68</b>
S1	232.4	40.81	( 23.7 )	( 4.161 )	0.18 ~ 0.36	2.6	4,320	<b>SS2- 70</b>
S1	240.2	43.34	( 24.49 )	( 4.419 )	0.18 ~ 0.36	2.7	4,800	<b>SS2- 72</b>
S1	251.7	47.29	( 25.67 )	( 4.822 )	0.18 ~ 0.36	2.9	4,860	<b>SS2- 75</b>
S1	255.7	48.64	( 26.07 )	( 4.96 )	0.18 ~ 0.36	3.1	4,900	<b>SS2- 76</b>
S2	271.2	54.26	( 27.65 )	( 5.533 )	0.18 ~ 0.36	2.6	5,370	<b>SS2- 80</b>
S2	286.7	60.2	( 29.24 )	( 6.139 )	0.2 ~ 0.44	3	5,930	<b>SS2- 84</b>
S2	290.7	61.73	( 29.64 )	( 6.295 )	0.2 ~ 0.44	3	6,040	<b>SS2- 85</b>
S2	302.3	66.46	( 30.83 )	( 6.777 )	0.2 ~ 0.44	3.4	6,560	<b>SS2- 88</b>
S2	310.2	69.7	( 31.63 )	( 7.108 )	0.2 ~ 0.44	3.4	6,590	<b>SS2- 90</b>
S2	329.7	78.19	( 33.62 )	( 7.973 )	0.2 ~ 0.44	3.7	7,320	<b>SS2- 95</b>
S2	291.1	72.74	( 29.68 )	( 7.418 )	0.2 ~ 0.44	3.8	8,300	<b>SS2-100</b>
S2	356.5	107.7	( 36.35 )	( 10.98 )	0.2 ~ 0.44	6.2	11,660	<b>SS2-120</b>
S1	454.9	174	( 46.39 )	( 17.74 )	0.2 ~ 0.44	14.5	16,330	<b>SS2-150</b>

【注1】表記の許容トルクは任意の使用条件で計算した参考値です。詳細については27頁をご参照ください。

【注2】バックラッシは同一型番どうし理論値で組立てたときの数値です。





# SS平歯車 モジュール 2.5

平歯車  
SS

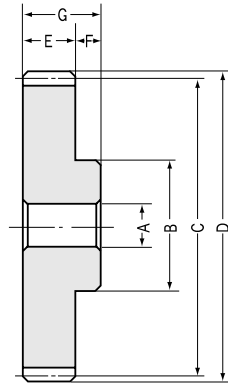

S1形状

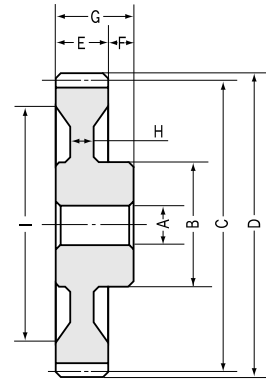

S2形状

## モジュール 2.5

カタログ記号	モジュール	歯数	穴径	ボス径	基準円直径	歯先円直径	歯幅	ボス長さ	全長	ウェブ厚	リム径
	<i>m</i>	<i>z</i>	AH7	B	C	D	E	F	G	H	I
<b>SS2.5-12</b>	2.5	12	12	23	30	35	25	12	37		
<b>SS2.5-13</b>	2.5	13	12	25	32.5	37.5	25	12	37		
<b>SS2.5-14</b>	2.5	14	12	25	35	40	25	12	37		
<b>SS2.5-15</b>	2.5	15	15	30	37.5	42.5	25	12	37		
<b>SS2.5-16</b>	2.5	16	15	32	40	45	25	12	37		
<b>SS2.5-17</b>	2.5	17	15	35	42.5	47.5	25	12	37		
<b>SS2.5-18</b>	2.5	18	15	38	45	50	25	12	37		
<b>SS2.5-19</b>	2.5	19	15	39	47.5	52.5	25	12	37		
<b>SS2.5-20</b>	2.5	20	15	40	50	55	25	12	37		
<b>SS2.5-21</b>	2.5	21	15	42	52.5	57.5	25	12	37		
<b>SS2.5-22</b>	2.5	22	15	44	55	60	25	12	37		
<b>SS2.5-23</b>	2.5	23	15	46	57.5	62.5	25	12	37		
<b>SS2.5-24</b>	2.5	24	15	48	60	65	25	12	37		
<b>SS2.5-25</b>	2.5	25	15	50	62.5	67.5	25	12	37		
<b>SS2.5-26</b>	2.5	26	15	55	65	70	25	12	37		
<b>SS2.5-27</b>	2.5	27	15	60	67.5	72.5	25	12	37		
<b>SS2.5-28</b>	2.5	28	15	60	70	75	25	12	37		
<b>SS2.5-29</b>	2.5	29	15	62	72.5	77.5	25	12	37		
<b>SS2.5-30</b>	2.5	30	15	65	75	80	25	12	37		
<b>SS2.5-32</b>	2.5	32	15	70	80	85	25	12	37		
<b>SS2.5-34</b>	2.5	34	15	70	85	90	25	12	37		
<b>SS2.5-35</b>	2.5	35	15	70	87.5	92.5	25	12	37		
<b>SS2.5-36</b>	2.5	36	15	70	90	95	25	12	37		
<b>SS2.5-38</b>	2.5	38	20	70	95	100	25	12	37		
<b>SS2.5-40</b>	2.5	40	20	70	100	105	25	12	37		
<b>SS2.5-42</b>	2.5	42	20	70	105	110	25	12	37		
<b>SS2.5-44</b>	2.5	44	20	70	110	115	25	12	37		
<b>SS2.5-45</b>	2.5	45	20	70	112.5	117.5	25	12	37		
<b>SS2.5-46</b>	2.5	46	20	70	115	120	25	12	37		
<b>SS2.5-48</b>	2.5	48	20	70	120	125	25	12	37		
<b>SS2.5-50</b>	2.5	50	20	70	125	130	25	12	37		
<b>SS2.5-52</b>	2.5	52	20	70	130	135	25	12	37		
<b>SS2.5-54</b>	2.5	54	20	70	135	140	25	12	37		
<b>SS2.5-55</b>	2.5	55	20	70	137.5	142.5	25	12	37		
<b>SS2.5-56</b>	2.5	56	20	70	140	145	25	12	37		
<b>SS2.5-58</b>	2.5	58	20	70	145	150	25	12	37		
<b>SS2.5-60</b>	2.5	60	25	70	150	155	25	12	37	10	127
<b>SS2.5-62</b>	2.5	62	25	80	155	160	25	12	37	15	130
<b>SS2.5-64</b>	2.5	64	25	80	160	165	25	12	37	15	131
<b>SS2.5-65</b>	2.5	65	25	80	162.5	167.5	25	12	37	15	134
<b>SS2.5-66</b>	2.5	66	25	80	165	170	25	12	37	15	140
<b>SS2.5-68</b>	2.5	68	25	80	170	175	25	12	37	15	140
<b>SS2.5-70</b>	2.5	70	25	80	175	180	25	12	37	15	146
<b>SS2.5-72</b>	2.5	72	25	80	180	185	25	12	37	15	151
<b>SS2.5-75</b>	2.5	75	25	80	187.5	192.5	25	12	37	15	159
<b>SS2.5-76</b>	2.5	76	25	80	190	195	25	12	37	15	160
<b>SS2.5-80</b>	2.5	80	25	80	200	205	25	12	37	10	177
<b>SS2.5-90</b>	2.5	90	30	90	225	230	25	12	37	10	202
<b>SS2.5-100</b>	2.5	100	30	90	250	255	25	12	37	10	227
<b>SS2.5-120</b>	2.5	120	30	100	300	305	25	12	37	10	277

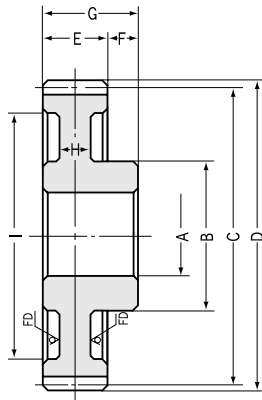

S4形状

\* FDは型鍛造仕上げ面です。

## 共通仕様

精度等級	JIS N8級 (JIS B 1702-1:1998) 旧JIS 4級 (JIS B 1702:1976)	歯面硬度	194HB以下
歯形	並歯	表面処理	黒染
圧力角	20°	歯面仕上げ	切削
材料	S45C	歯切基準面	穴
熱処理		追加工	可能

形状	許容トルク(N・m) 注1		許容トルク(kgf・m)		バックラッシ (mm) 注2	質量 (kg)	価格 (円)	カタログ記号
	曲げ強さ	歯面強さ	曲げ強さ	歯面強さ				
S1	39.77	1.766	( 4.055 )	( 0.1801 )	0.14 ~ 0.28	0.14	810	<b>SS2.5- 12</b>
S1	45.61	2.138	( 4.651 )	( 0.218 )	0.14 ~ 0.28	0.17	840	<b>SS2.5- 13</b>
S1	51.61	2.532	( 5.263 )	( 0.2582 )	0.14 ~ 0.28	0.2	880	<b>SS2.5- 14</b>
S1	57.73	2.964	( 5.887 )	( 0.3022 )	0.14 ~ 0.28	0.23	910	<b>SS2.5- 15</b>
S1	63.96	3.429	( 6.522 )	( 0.3497 )	0.14 ~ 0.28	0.25	990	<b>SS2.5- 16</b>
S1	70.29	3.932	( 7.168 )	( 0.401 )	0.14 ~ 0.28	0.28	1,050	<b>SS2.5- 17</b>
S1	76.72	4.471	( 7.823 )	( 0.4559 )	0.14 ~ 0.28	0.35	1,150	<b>SS2.5- 18</b>
S1	83.22	5.045	( 8.486 )	( 0.5145 )	0.14 ~ 0.28	0.4	1,210	<b>SS2.5- 19</b>
S1	89.79	5.656	( 9.156 )	( 0.5768 )	0.14 ~ 0.28	0.44	1,260	<b>SS2.5- 20</b>
S1	96.44	6.304	( 9.834 )	( 0.6428 )	0.16 ~ 0.34	0.49	1,300	<b>SS2.5- 21</b>
S1	103.2	6.987	( 10.52 )	( 0.7125 )	0.16 ~ 0.34	0.53	1,420	<b>SS2.5- 22</b>
S1	109.9	7.708	( 11.21 )	( 0.786 )	0.16 ~ 0.34	0.58	1,460	<b>SS2.5- 23</b>
S1	116.7	8.465	( 11.9 )	( 0.8632 )	0.16 ~ 0.34	0.65	1,540	<b>SS2.5- 24</b>
S1	123.6	9.259	( 12.6 )	( 0.9442 )	0.16 ~ 0.34	0.7	1,570	<b>SS2.5- 25</b>
S1	130.4	10.05	( 13.3 )	( 1.025 )	0.16 ~ 0.34	0.83	1,680	<b>SS2.5- 26</b>
S1	137.4	10.88	( 14.01 )	( 1.109 )	0.16 ~ 0.34	0.92	1,730	<b>SS2.5- 27</b>
S1	144.4	11.74	( 14.72 )	( 1.197 )	0.16 ~ 0.34	1	1,840	<b>SS2.5- 28</b>
S1	151.4	12.64	( 15.44 )	( 1.289 )	0.16 ~ 0.34	1.1	1,890	<b>SS2.5- 29</b>
S1	158.5	13.58	( 16.16 )	( 1.385 )	0.16 ~ 0.34	1.2	2,000	<b>SS2.5- 30</b>
S1	172.6	15.56	( 17.6 )	( 1.587 )	0.16 ~ 0.34	1.3	2,220	<b>SS2.5- 32</b>
S1	186.9	17.69	( 19.06 )	( 1.804 )	0.16 ~ 0.34	1.4	2,410	<b>SS2.5- 34</b>
S1	194.1	18.81	( 19.79 )	( 1.918 )	0.16 ~ 0.34	1.5	2,440	<b>SS2.5- 35</b>
S1	201.3	19.96	( 20.53 )	( 2.035 )	0.16 ~ 0.34	1.6	2,550	<b>SS2.5- 36</b>
S1	215.7	22.37	( 22 )	( 2.281 )	0.16 ~ 0.34	1.7	2,900	<b>SS2.5- 38</b>
S1	230.4	24.92	( 23.49 )	( 2.541 )	0.16 ~ 0.34	1.8	3,020	<b>SS2.5- 40</b>
S1	244.9	27.62	( 24.97 )	( 2.816 )	0.18 ~ 0.4	2	3,420	<b>SS2.5- 42</b>
S1	259.6	30.45	( 26.47 )	( 3.105 )	0.18 ~ 0.4	2.1	3,460	<b>SS2.5- 44</b>
S1	266.9	31.92	( 27.22 )	( 3.255 )	0.18 ~ 0.4	2.2	3,670	<b>SS2.5- 45</b>
S1	274.3	33.46	( 27.97 )	( 3.412 )	0.18 ~ 0.4	2.3	3,960	<b>SS2.5- 46</b>
S1	289.1	36.67	( 29.48 )	( 3.739 )	0.18 ~ 0.4	2.5	4,010	<b>SS2.5- 48</b>
S1	303.9	40.02	( 30.99 )	( 4.081 )	0.18 ~ 0.4	2.7	4,330	<b>SS2.5- 50</b>
S1	318.7	43.53	( 32.5 )	( 4.439 )	0.18 ~ 0.4	3	4,390	<b>SS2.5- 52</b>
S1	333.6	47.19	( 34.02 )	( 4.812 )	0.18 ~ 0.4	3.1	4,730	<b>SS2.5- 54</b>
S1	341.1	49.08	( 34.78 )	( 5.005 )	0.18 ~ 0.4	3.2	4,820	<b>SS2.5- 55</b>
S1	348.6	51	( 35.55 )	( 5.201 )	0.18 ~ 0.4	3.3	4,870	<b>SS2.5- 56</b>
S1	363.5	54.98	( 37.07 )	( 5.606 )	0.18 ~ 0.4	3.7	5,560	<b>SS2.5- 58</b>
S4	378.5	59.1	( 38.6 )	( 6.027 )	0.18 ~ 0.4	2.7	5,640	<b>SS2.5- 60</b>
S2	393.5	63.39	( 40.13 )	( 6.464 )	0.18 ~ 0.4	3.1	6,240	<b>SS2.5- 62</b>
S2	408.6	67.82	( 41.67 )	( 6.916 )	0.18 ~ 0.4	3.5	6,380	<b>SS2.5- 64</b>
S2	416.1	70.1	( 42.43 )	( 7.148 )	0.18 ~ 0.4	3.7	6,690	<b>SS2.5- 65</b>
S2	423.6	72.42	( 43.2 )	( 7.385 )	0.18 ~ 0.4	3.9	6,890	<b>SS2.5- 66</b>
S2	438.7	77.17	( 44.74 )	( 7.869 )	0.18 ~ 0.4	4.1	6,940	<b>SS2.5- 68</b>
S2	453.8	82.07	( 46.28 )	( 8.369 )	0.18 ~ 0.4	4.2	7,610	<b>SS2.5- 70</b>
S2	468.9	87.14	( 47.82 )	( 8.886 )	0.18 ~ 0.4	4.4	7,710	<b>SS2.5- 72</b>
S2	491.7	95.03	( 50.14 )	( 9.69 )	0.18 ~ 0.4	4.7	8,530	<b>SS2.5- 75</b>
S2	499.3	97.73	( 50.91 )	( 9.966 )	0.18 ~ 0.4	5	8,630	<b>SS2.5- 76</b>
S4	441.4	90.93	( 45.01 )	( 9.272 )	0.18 ~ 0.4	4.1	8,890	<b>SS2.5- 80</b>
S4	504.8	117.2	( 51.48 )	( 11.95 )	0.22 ~ 0.48	7.6	13,010	<b>SS2.5- 90</b>
S4	568.5	147	( 57.97 )	( 14.99 )	0.22 ~ 0.48	7.8	15,230	<b>SS2.5-100</b>
S4	696.3	217.5	( 71 )	( 22.18 )	0.22 ~ 0.48	11	21,200	<b>SS2.5-120</b>

【注1】表記の許容トルクは任意の使用条件で計算した参考値です。詳細については27頁をご参照ください。

【注2】バックラッシは同一型番どうし理論値で組立てたときの数値です。



# SS平歯車 モジュール 3

平歯車  
SS

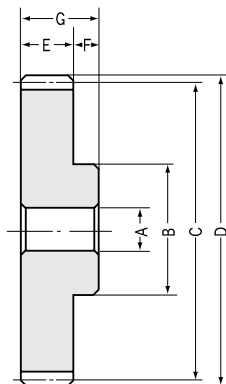

S1形状

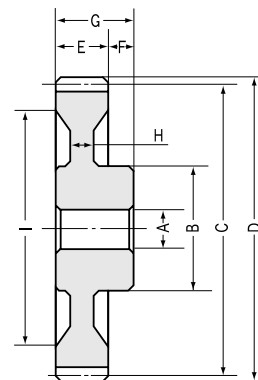

S2形状

## モジュール 3

カタログ記号	モジュール	歯数	穴径	ボス径	基準円直径	歯先円直径	歯幅	ボス長さ	全長	ウェブ厚	リム径
	<i>m</i>	<i>z</i>	AH7	B	C	D	E	F	G	H	I
SS3- 12	3	12	15	28	36	42	30	15	45		
SS3- 13	3	13	15	30	39	45	30	15	45		
SS3- 14	3	14	15	32	42	48	30	15	45		
SS3- 15	3	15	15	36	45	51	30	15	45		
SS3- 16	3	16	15	38	48	54	30	15	45		
SS3- 17	3	17	15	39	51	57	30	15	45		
SS3- 18	3	18	15	40	54	60	30	15	45		
SS3- 19	3	19	15	45	57	63	30	15	45		
SS3- 20	3	20	15	50	60	66	30	15	45		
SS3- 21	3	21	15	52	63	69	30	15	45		
SS3- 22	3	22	15	54	66	72	30	15	45		
SS3- 23	3	23	15	56	69	75	30	15	45		
SS3- 24	3	24	15	58	72	78	30	15	45		
SS3- 25	3	25	20	60	75	81	30	15	45		
SS3- 26	3	26	20	65	78	84	30	15	45		
SS3- 27	3	27	20	65	81	87	30	15	45		
SS3- 28	3	28	20	70	84	90	30	15	45		
SS3- 29	3	29	20	70	87	93	30	15	45		
SS3- 30	3	30	20	75	90	96	30	15	45		
SS3- 32	3	32	20	75	96	102	30	15	45		
SS3- 34	3	34	20	80	102	108	30	15	45		
SS3- 35	3	35	20	80	105	111	30	15	45		
SS3- 36	3	36	20	80	108	114	30	15	45		
SS3- 38	3	38	25	80	114	120	30	15	45		
SS3- 40	3	40	25	80	120	126	30	15	45		
SS3- 42	3	42	25	80	126	132	30	15	45		
SS3- 44	3	44	25	80	132	138	30	15	45		
SS3- 45	3	45	25	80	135	141	30	15	45		
SS3- 46	3	46	25	80	138	144	30	15	45		
SS3- 48	3	48	25	80	144	150	30	15	45		
SS3- 50	3	50	25	80	150	156	30	15	45	10	123
SS3- 52	3	52	25	80	156	162	30	15	45	16	126
SS3- 54	3	54	25	80	162	168	30	15	45	16	132
SS3- 55	3	55	25	80	165	171	30	15	45	16	131
SS3- 56	3	56	25	80	168	174	30	15	45	16	134
SS3- 58	3	58	25	80	174	180	30	15	45	16	144
SS3- 60	3	60	25	80	180	186	30	15	45	10	153
SS3- 62	3	62	25	80	186	192	30	15	45	16	150
SS3- 64	3	64	25	80	192	198	30	15	45	16	158
SS3- 65	3	65	25	80	195	201	30	15	45	16	161
SS3- 66	3	66	25	90	198	204	30	15	45	16	160
SS3- 68	3	68	25	90	204	210	30	15	45	16	170
SS3- 70	3	70	25	90	210	216	30	15	45	16	176
SS3- 72	3	72	25	90	216	222	30	15	45	16	182
SS3- 75	3	75	25	90	225	231	30	15	45	16	190
SS3- 76	3	76	25	90	228	234	30	15	45	16	190
SS3- 80	3	80	30	90	240	246	30	15	45	10	213
SS3- 90	3	90	30	100	270	276	30	15	45	16	240
SS3-100	3	100	30	100	300	306	30	15	45	10	273
SS3-120	3	120	30	130	360	366	30	15	45	10	333

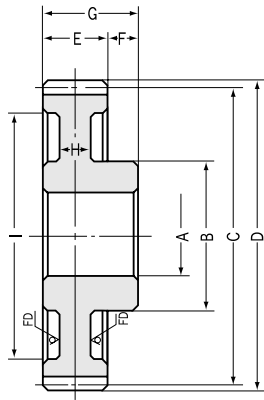

S4形状

\*FDは型鍛造仕上げ面です。

## 共通仕様

精度等級	JIS N8級 (JIS B 1702-1:1998) 旧JIS 4級 (JIS B 1702:1976)	歯面硬度	194HB以下
歯形	並歯	表面処理	黒染
圧力角	20°	歯面仕上げ	切削
材料	S45C	歯切基準面	穴
熱処理		追加工	可能

形状	許容トルク(N・m) 注1		許容トルク(kgf・m)		バックラッシ (mm) 注2	質量 (kg)	価格 (円)	カタログ記号
	曲げ強さ	歯面強さ	曲げ強さ	歯面強さ				
S1	68.71	3.116	( 7.007 )	( 0.3177 )	0.14 ~ 0.32	0.25	1,000	<b>SS3- 12</b>
S1	78.83	3.773	( 8.038 )	( 0.3847 )	0.14 ~ 0.32	0.3	1,110	<b>SS3- 13</b>
S1	89.18	4.468	( 9.094 )	( 0.4556 )	0.14 ~ 0.32	0.35	1,160	<b>SS3- 14</b>
S1	99.73	5.225	( 10.17 )	( 0.5328 )	0.14 ~ 0.32	0.4	1,340	<b>SS3- 15</b>
S1	110.5	6.045	( 11.27 )	( 0.6164 )	0.14 ~ 0.32	0.5	1,370	<b>SS3- 16</b>
S1	121.5	6.926	( 12.39 )	( 0.7063 )	0.14 ~ 0.32	0.65	1,410	<b>SS3- 17</b>
S1	132.6	7.872	( 13.52 )	( 0.8027 )	0.14 ~ 0.32	0.67	1,600	<b>SS3- 18</b>
S1	143.8	8.88	( 14.66 )	( 0.9055 )	0.14 ~ 0.32	0.73	1,610	<b>SS3- 19</b>
S1	155.1	9.954	( 15.82 )	( 1.015 )	0.14 ~ 0.32	0.8	1,710	<b>SS3- 20</b>
S1	166.6	11.09	( 16.99 )	( 1.131 )	0.18 ~ 0.38	1	1,850	<b>SS3- 21</b>
S1	178.2	12.29	( 18.17 )	( 1.253 )	0.18 ~ 0.38	1.1	1,970	<b>SS3- 22</b>
S1	189.9	13.55	( 19.36 )	( 1.382 )	0.18 ~ 0.38	1.1	2,110	<b>SS3- 23</b>
S1	201.6	14.89	( 20.56 )	( 1.518 )	0.18 ~ 0.38	1.2	2,150	<b>SS3- 24</b>
S1	213.5	16.3	( 21.77 )	( 1.662 )	0.18 ~ 0.38	1.3	2,310	<b>SS3- 25</b>
S1	225.5	17.7	( 22.99 )	( 1.805 )	0.18 ~ 0.38	1.5	2,470	<b>SS3- 26</b>
S1	237.4	19.17	( 24.21 )	( 1.955 )	0.18 ~ 0.38	1.6	2,600	<b>SS3- 27</b>
S1	249.5	20.7	( 25.44 )	( 2.111 )	0.18 ~ 0.38	1.7	2,670	<b>SS3- 28</b>
S1	261.6	22.3	( 26.68 )	( 2.274 )	0.18 ~ 0.38	1.7	2,700	<b>SS3- 29</b>
S1	273.8	23.95	( 27.92 )	( 2.442 )	0.18 ~ 0.38	1.8	2,790	<b>SS3- 30</b>
S1	298.3	27.44	( 30.42 )	( 2.798 )	0.18 ~ 0.38	2.1	3,240	<b>SS3- 32</b>
S1	323	31.18	( 32.94 )	( 3.179 )	0.18 ~ 0.38	2.4	3,640	<b>SS3- 34</b>
S1	335.4	33.14	( 34.2 )	( 3.379 )	0.18 ~ 0.38	2.5	3,670	<b>SS3- 35</b>
S1	347.8	35.16	( 35.47 )	( 3.585 )	0.18 ~ 0.38	2.6	3,710	<b>SS3- 36</b>
S1	372.8	39.4	( 38.02 )	( 4.018 )	0.18 ~ 0.38	3	4,200	<b>SS3- 38</b>
S1	397.9	43.99	( 40.58 )	( 4.486 )	0.18 ~ 0.38	3.1	4,240	<b>SS3- 40</b>
S1	423.3	48.85	( 43.16 )	( 4.981 )	0.2 ~ 0.44	3.4	4,670	<b>SS3- 42</b>
S1	448.6	53.97	( 45.74 )	( 5.503 )	0.2 ~ 0.44	3.7	5,110	<b>SS3- 44</b>
S1	461.3	56.63	( 47.04 )	( 5.775 )	0.2 ~ 0.44	3.8	5,170	<b>SS3- 45</b>
S1	474	59.36	( 48.34 )	( 6.053 )	0.2 ~ 0.44	4.2	5,250	<b>SS3- 46</b>
S1	499.5	65.01	( 50.94 )	( 6.629 )	0.2 ~ 0.44	4.3	5,810	<b>SS3- 48</b>
S4	525.1	70.92	( 53.55 )	( 7.232 )	0.2 ~ 0.44	3.6	6,570	<b>SS3- 50</b>
S2	550.8	77.11	( 56.17 )	( 7.863 )	0.2 ~ 0.44	4.5	6,730	<b>SS3- 52</b>
S2	576.5	83.57	( 58.79 )	( 8.522 )	0.2 ~ 0.44	4.6	7,110	<b>SS3- 54</b>
S2	589.5	86.9	( 60.11 )	( 8.861 )	0.2 ~ 0.44	4.8	7,210	<b>SS3- 55</b>
S2	602.3	90.3	( 61.42 )	( 9.208 )	0.2 ~ 0.44	4.8	7,330	<b>SS3- 56</b>
S2	628.2	97.29	( 64.06 )	( 9.921 )	0.2 ~ 0.44	5.5	7,930	<b>SS3- 58</b>
S4	654.1	104.5	( 66.7 )	( 10.66 )	0.2 ~ 0.44	4.5	8,000	<b>SS3- 60</b>
S2	680.1	112.1	( 69.35 )	( 11.43 )	0.2 ~ 0.44	6	8,870	<b>SS3- 62</b>
S2	588.4	99.93	( 60 )	( 10.19 )	0.2 ~ 0.44	6.2	10,490	<b>SS3- 64</b>
S2	599.2	103.4	( 61.1 )	( 10.54 )	0.2 ~ 0.44	6.3	10,510	<b>SS3- 65</b>
S2	610.1	106.8	( 62.21 )	( 10.89 )	0.2 ~ 0.44	6.5	10,600	<b>SS3- 66</b>
S2	631.8	113.9	( 64.43 )	( 11.61 )	0.2 ~ 0.44	6.8	11,180	<b>SS3- 68</b>
S2	653.5	121.2	( 66.64 )	( 12.36 )	0.2 ~ 0.44	7.4	11,380	<b>SS3- 70</b>
S2	675.3	128.8	( 68.86 )	( 13.13 )	0.2 ~ 0.44	7.6	12,440	<b>SS3- 72</b>
S2	708	140.6	( 72.2 )	( 14.34 )	0.2 ~ 0.44	8	13,500	<b>SS3- 75</b>
S2	718.9	144.7	( 73.31 )	( 14.76 )	0.2 ~ 0.44	8.7	13,590	<b>SS3- 76</b>
S4	762.7	161.6	( 77.77 )	( 16.48 )	0.2 ~ 0.44	7.2	13,690	<b>SS3- 80</b>
S2	872.3	208.2	( 88.95 )	( 21.23 )	0.26 ~ 0.52	10.5	19,760	<b>SS3- 90</b>
S4	982.6	261.1	( 100.2 )	( 26.62 )	0.26 ~ 0.52	10.2	24,100	<b>SS3-100</b>
S4	1203	386.1	( 122.7 )	( 39.37 )	0.26 ~ 0.52	14.9	37,490	<b>SS3-120</b>

【注1】表記の許容トルクは任意の使用条件で計算した参考値です。詳細については27頁をご参照ください。

【注2】バックラッシは同一型番どうし理論値で組立てたときの数値です。



# SS平歯車 モジュール 4

平歯車

SS

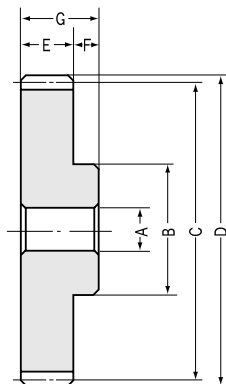

S1形状

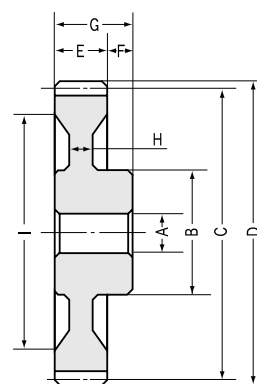

S2形状

## モジュール 4

カタログ記号	モジュール	歯数	穴径	ボス径	基準円直径	歯先円直径	歯幅	ボス長さ	全長	ウェブ厚	リム径
	m	z	AH7	B	C	D	E	F	G	H	I
SS4-12	4	12	20	35	48	56	40	20	60		
SS4-13	4	13	20	38	52	60	40	20	60		
SS4-14	4	14	20	40	56	64	40	20	60		
SS4-15	4	15	20	45	60	68	40	20	60		
SS4-16	4	16	20	50	64	72	40	20	60		
SS4-17	4	17	20	53	68	76	40	20	60		
SS4-18	4	18	20	55	72	80	40	20	60		
SS4-19	4	19	20	60	76	84	40	20	60		
SS4-20	4	20	20	65	80	88	40	20	60		
SS4-21	4	21	20	69	84	92	40	20	60		
SS4-22	4	22	20	73	88	96	40	20	60		
SS4-23	4	23	20	77	92	100	40	20	60		
SS4-24	4	24	20	80	96	104	40	20	60		
SS4-25	4	25	20	84	100	108	40	20	60		
SS4-26	4	26	20	87	104	112	40	20	60		
SS4-27	4	27	20	90	108	116	40	20	60		
SS4-28	4	28	20	95	112	120	40	20	60		
SS4-29	4	29	20	95	116	124	40	20	60		
SS4-30	4	30	20	100	120	128	40	20	60		
SS4-32	4	32	22	100	128	136	40	16	56		
SS4-34	4	34	22	100	136	144	40	16	56		
SS4-35	4	35	22	100	140	148	40	16	56		
SS4-36	4	36	22	100	144	152	40	16	56		
SS4-38	4	38	22	100	152	160	40	16	56		
SS4-40	4	40	25	100	160	168	40	16	56		
SS4-42	4	42	25	100	168	176	40	16	56		
SS4-44	4	44	25	100	176	184	40	16	56		
SS4-45	4	45	25	100	180	188	40	16	56		
SS4-46	4	46	25	100	184	192	40	16	56		
SS4-48	4	48	25	100	192	200	40	16	56	26	150
SS4-50	4	50	30	100	200	208	40	16	56	12	168
SS4-52	4	52	30	100	208	216	40	16	56	26	165
SS4-54	4	54	30	100	216	224	40	16	56	26	175
SS4-55	4	55	30	100	220	228	40	16	56	26	178
SS4-56	4	56	30	100	224	232	40	16	56	26	182
SS4-58	4	58	30	110	232	240	40	16	56	26	190
SS4-60	4	60	30	110	240	248	40	16	56	12	208
SS4-62	4	62	30	110	248	256	40	16	56	20	210
SS4-64	4	64	30	110	256	264	40	16	56	16	214
SS4-65	4	65	30	110	260	268	40	16	56	16	218
SS4-66	4	66	30	120	264	272	40	16	56	16	220
SS4-68	4	68	30	120	272	280	40	16	56	16	225
SS4-70	4	70	30	120	280	288	40	16	56	12	248
SS4-80	4	80	30	120	320	328	40	16	56	12	288

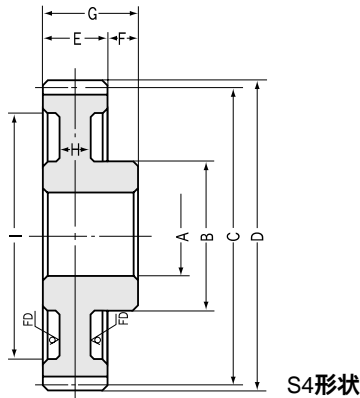

\*FDは型鍛造仕上げ面です。

## 共通仕様

精度等級	JIS N8級 (JIS B 1702-1:1998) 旧JIS 4級 (JIS B 1702:1976)	歯面硬度	194HB以下
歯形	並歯	表面処理	黒染
圧力角	20°	歯面仕上げ	切削
材料	S45C	歯切基準面	穴
熱処理		追加工	可能

形状	許容トルク(N・m) 注1		許容トルク(kgf・m)		バックラッシ (mm) 注2	質量 (kg)	価格 (円)	カタログ記号
	曲げ強さ	歯面強さ	曲げ強さ	歯面強さ				
S1	162.9	7.624	( 16.61 )	( 0.7774 )	0.18 ~ 0.38	0.55	1,730	<b>SS4-12</b>
S1	186.8	9.222	( 19.05 )	( 0.9404 )	0.18 ~ 0.38	0.67	1,890	<b>SS4-13</b>
S1	211.4	10.91	( 21.56 )	( 1.113 )	0.18 ~ 0.38	0.8	2,060	<b>SS4-14</b>
S1	236.4	12.75	( 24.11 )	( 1.3 )	0.18 ~ 0.38	0.95	2,120	<b>SS4-15</b>
S1	261.9	14.74	( 26.71 )	( 1.503 )	0.18 ~ 0.38	1.1	2,340	<b>SS4-16</b>
S1	287.9	16.88	( 29.36 )	( 1.721 )	0.18 ~ 0.38	1.3	2,540	<b>SS4-17</b>
S1	314.2	19.18	( 32.04 )	( 1.956 )	0.18 ~ 0.38	1.5	2,740	<b>SS4-18</b>
S1	340.9	21.66	( 34.76 )	( 2.209 )	0.18 ~ 0.38	1.7	2,940	<b>SS4-19</b>
S1	367.7	24.3	( 37.5 )	( 2.478 )	0.18 ~ 0.38	1.9	3,120	<b>SS4-20</b>
S1	395	27.1	( 40.28 )	( 2.763 )	0.2 ~ 0.44	2.2	3,250	<b>SS4-21</b>
S1	422.5	30.05	( 43.08 )	( 3.064 )	0.2 ~ 0.44	2.4	3,420	<b>SS4-22</b>
S1	450.1	33.17	( 45.9 )	( 3.382 )	0.2 ~ 0.44	2.6	3,850	<b>SS4-23</b>
S1	478.1	36.44	( 48.75 )	( 3.716 )	0.2 ~ 0.44	2.9	3,960	<b>SS4-24</b>
S1	506.1	39.87	( 51.61 )	( 4.066 )	0.2 ~ 0.44	3.2	4,350	<b>SS4-25</b>
S1	534.4	43.31	( 54.49 )	( 4.416 )	0.2 ~ 0.44	3.5	4,720	<b>SS4-26</b>
S1	562.8	46.89	( 57.39 )	( 4.781 )	0.2 ~ 0.44	3.8	4,790	<b>SS4-27</b>
S1	591.4	50.6	( 60.31 )	( 5.16 )	0.2 ~ 0.44	4.2	5,240	<b>SS4-28</b>
S1	620.2	54.54	( 63.24 )	( 5.562 )	0.2 ~ 0.44	4.4	5,270	<b>SS4-29</b>
S1	649	58.66	( 66.18 )	( 5.982 )	0.2 ~ 0.44	4.5	5,630	<b>SS4-30</b>
S1	707.1	67.37	( 72.1 )	( 6.87 )	0.2 ~ 0.44	4.8	5,820	<b>SS4-32</b>
S1	765.6	76.71	( 78.07 )	( 7.822 )	0.2 ~ 0.44	5.5	6,080	<b>SS4-34</b>
S1	795	81.61	( 81.07 )	( 8.322 )	0.2 ~ 0.44	5.6	6,810	<b>SS4-35</b>
S1	824.5	86.67	( 84.08 )	( 8.838 )	0.2 ~ 0.44	5.7	6,870	<b>SS4-36</b>
S1	883.8	97.28	( 90.12 )	( 9.92 )	0.2 ~ 0.44	7.1	7,670	<b>SS4-38</b>
S1	943.4	108.6	( 96.2 )	( 11.07 )	0.2 ~ 0.44	7.2	8,450	<b>SS4-40</b>
S1	1003	120.4	( 102.3 )	( 12.28 )	0.24 ~ 0.52	7.7	8,590	<b>SS4-42</b>
S1	1063	132.9	( 108.4 )	( 13.55 )	0.24 ~ 0.52	8.2	9,450	<b>SS4-44</b>
S1	1093	139.4	( 111.5 )	( 14.22 )	0.24 ~ 0.52	8.8	10,410	<b>SS4-45</b>
S1	1124	146.1	( 114.6 )	( 14.9 )	0.24 ~ 0.52	9.7	10,530	<b>SS4-46</b>
S2	986.5	133.3	( 100.6 )	( 13.59 )	0.24 ~ 0.52	9	12,050	<b>SS4-48</b>
S4	1038	145.5	( 105.8 )	( 14.84 )	0.24 ~ 0.52	7.8	13,210	<b>SS4-50</b>
S2	1088	158.3	( 110.9 )	( 16.14 )	0.24 ~ 0.52	10	13,400	<b>SS4-52</b>
S2	1139	171.7	( 116.1 )	( 17.51 )	0.24 ~ 0.52	10.5	14,400	<b>SS4-54</b>
S2	1164	178.7	( 118.7 )	( 18.22 )	0.24 ~ 0.52	11	15,660	<b>SS4-55</b>
S2	1190	185.7	( 121.3 )	( 18.94 )	0.24 ~ 0.52	11.5	15,750	<b>SS4-56</b>
S2	1241	200.2	( 126.5 )	( 20.42 )	0.24 ~ 0.52	12	17,120	<b>SS4-58</b>
S4	1293	215.4	( 131.8 )	( 21.97 )	0.24 ~ 0.52	10.5	17,450	<b>SS4-60</b>
S2	1343	231.1	( 137 )	( 23.57 )	0.24 ~ 0.52	12.5	18,850	<b>SS4-62</b>
S2	1394	247.5	( 142.2 )	( 25.24 )	0.24 ~ 0.52	12.5	21,010	<b>SS4-64</b>
S2	1420	256	( 144.8 )	( 26.1 )	0.24 ~ 0.52	12.8	22,550	<b>SS4-65</b>
S2	1446	264.5	( 147.5 )	( 26.97 )	0.24 ~ 0.52	13	22,940	<b>SS4-66</b>
S2	1497	281.9	( 152.7 )	( 28.75 )	0.24 ~ 0.52	14	23,890	<b>SS4-68</b>
S4	1549	300.1	( 158 )	( 30.6 )	0.24 ~ 0.52	14.4	25,730	<b>SS4-70</b>
S4	1808	399.7	( 184.4 )	( 40.76 )	0.24 ~ 0.52	19	33,540	<b>SS4-80</b>

【注1】表記の許容トルクは任意の使用条件で計算した参考値です。詳細については27頁をご参照ください。

【注2】バックラッシは同一型番どうし理論値で組立てたときの数値です。



# SS平歯車 モジュール 5

平歯車  
SS

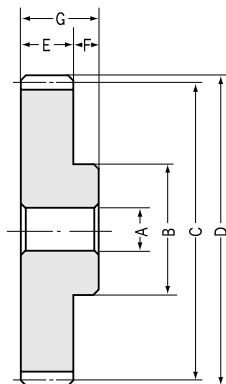

S1形状

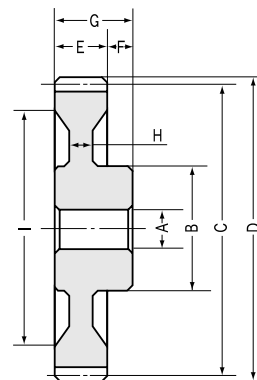

S2形状

## モジュール 5

カタログ記号	モジュール	歯数	穴径	ボス径	基準円直径	歯先円直径	歯幅	ボス長さ	全長	ウェブ厚	リム径
	m	z	AH7	B	C	D	E	F	G	H	I
<b>SS5-12</b>	5	12	22	46	60	70	50	25	75		
<b>SS5-13</b>	5	13	22	50	65	75	50	25	75		
<b>SS5-14</b>	5	14	22	52	70	80	50	25	75		
<b>SS5-15</b>	5	15	22	60	75	85	50	25	75		
<b>SS5-16</b>	5	16	22	65	80	90	50	25	75		
<b>SS5-17</b>	5	17	22	68	85	95	50	25	75		
<b>SS5-18</b>	5	18	22	70	90	100	50	25	75		
<b>SS5-19</b>	5	19	22	76	95	105	50	25	75		
<b>SS5-20</b>	5	20	22	82	100	110	50	25	75		
<b>SS5-21</b>	5	21	25	90	105	115	50	25	75		
<b>SS5-22</b>	5	22	25	95	110	120	50	25	75		
<b>SS5-23</b>	5	23	25	100	115	125	50	25	75		
<b>SS5-24</b>	5	24	25	100	120	130	50	25	75		
<b>SS5-25</b>	5	25	25	105	125	135	50	25	75		
<b>SS5-26</b>	5	26	25	110	130	140	50	25	75		
<b>SS5-27</b>	5	27	25	110	135	145	50	25	75		
<b>SS5-28</b>	5	28	25	110	140	150	50	25	75		
<b>SS5-29</b>	5	29	25	115	145	155	50	25	75		
<b>SS5-30</b>	5	30	25	120	150	160	50	25	75		
<b>SS5-32</b>	5	32	30	120	160	170	50	21	71		
<b>SS5-34</b>	5	34	30	120	170	180	50	21	71		
<b>SS5-35</b>	5	35	30	120	175	185	50	21	71		
<b>SS5-36</b>	5	36	30	120	180	190	50	21	71		
<b>SS5-38</b>	5	38	30	120	190	200	50	21	71		
<b>SS5-40</b>	5	40	30	120	200	210	50	21	71	36	160
<b>SS5-42</b>	5	42	30	120	210	220	50	21	71	36	170
<b>SS5-44</b>	5	44	30	120	220	230	50	21	71	36	175
<b>SS5-45</b>	5	45	30	120	225	235	50	21	71	36	185
<b>SS5-46</b>	5	46	30	120	230	240	50	21	71	30	185
<b>SS5-48</b>	5	48	30	120	240	250	50	21	71	30	200
<b>SS5-50</b>	5	50	30	120	250	260	50	21	71	16	212
<b>SS5-52</b>	5	52	30	130	260	270	50	21	71	30	220
<b>SS5-54</b>	5	54	30	130	270	280	50	21	71	30	230
<b>SS5-55</b>	5	55	30	130	275	285	50	21	71	30	235
<b>SS5-56</b>	5	56	30	130	280	290	50	21	71	30	240
<b>SS5-58</b>	5	58	30	130	290	300	50	21	71	30	240
<b>SS5-60</b>	5	60	30	130	300	310	50	21	71	20	260

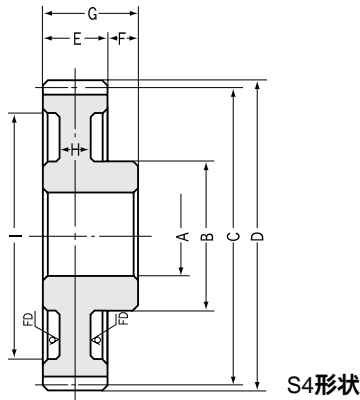

\*FDは型鍛造仕上げ面です。

## 共通仕様

精度等級	JIS N8級 (JIS B 1702-1:1998) 旧JIS 4級 (JIS B 1702:1976)	歯面硬度	194HB以下
歯形	並歯	表面処理	黒染
圧力角	20°	歯面仕上げ	切削
材 料	S45C	歯切基準面	穴
熱 処 理		追加工	可能

形状	許容トルク(N・m)注1		許容トルク(kgf・m)		バックラッシ (mm) 注2	質量 (kg)	価格 (円)	カタログ記号
	曲げ強さ	歯面強さ	曲げ強さ	歯面強さ				
S1	318.1	15.23	( 32.44 )	( 1.553 )	0.2 ~ 0.44	1.2	2,920	<b>SS5-12</b>
S1	364.9	18.41	( 37.21 )	( 1.877 )	0.2 ~ 0.44	1.5	3,160	<b>SS5-13</b>
S1	412.9	21.76	( 42.1 )	( 2.219 )	0.2 ~ 0.44	1.7	3,420	<b>SS5-14</b>
S1	461.8	25.46	( 47.09 )	( 2.596 )	0.2 ~ 0.44	2	3,670	<b>SS5-15</b>
S1	511.7	29.47	( 52.18 )	( 3.005 )	0.2 ~ 0.44	2.3	3,990	<b>SS5-16</b>
S1	562.3	33.79	( 57.34 )	( 3.446 )	0.2 ~ 0.44	2.6	4,190	<b>SS5-17</b>
S1	613.7	38.42	( 62.58 )	( 3.918 )	0.2 ~ 0.44	2.9	4,780	<b>SS5-18</b>
S1	665.8	43.37	( 67.89 )	( 4.423 )	0.2 ~ 0.44	3.5	4,900	<b>SS5-19</b>
S1	718.3	48.63	( 73.25 )	( 4.959 )	0.2 ~ 0.44	3.8	5,400	<b>SS5-20</b>
S1	771.5	54.2	( 78.67 )	( 5.527 )	0.24 ~ 0.5	4.4	5,500	<b>SS5-21</b>
S1	825.1	60.08	( 84.14 )	( 6.127 )	0.24 ~ 0.5	4.8	6,150	<b>SS5-22</b>
S1	879.2	66.34	( 89.65 )	( 6.765 )	0.24 ~ 0.5	5.5	6,270	<b>SS5-23</b>
S1	933.7	73.02	( 95.21 )	( 7.446 )	0.24 ~ 0.5	5.7	6,650	<b>SS5-24</b>
S1	988.5	80.04	( 100.8 )	( 8.162 )	0.24 ~ 0.5	6.1	6,740	<b>SS5-25</b>
S1	1043	87.05	( 106.4 )	( 8.877 )	0.24 ~ 0.5	6.6	7,480	<b>SS5-26</b>
S1	1099	94.38	( 112.1 )	( 9.624 )	0.24 ~ 0.5	7.6	7,620	<b>SS5-27</b>
S1	1155	102	( 117.8 )	( 10.4 )	0.24 ~ 0.5	8	8,600	<b>SS5-28</b>
S1	1211	109.9	( 123.5 )	( 11.21 )	0.24 ~ 0.5	8.2	8,700	<b>SS5-29</b>
S1	1268	118.2	( 129.3 )	( 12.05 )	0.24 ~ 0.5	8.8	9,560	<b>SS5-30</b>
S1	1381	135.6	( 140.8 )	( 13.83 )	0.24 ~ 0.5	9.8	10,360	<b>SS5-32</b>
S1	1495	154.4	( 152.5 )	( 15.74 )	0.24 ~ 0.5	11.8	11,610	<b>SS5-34</b>
S1	1552	164.2	( 158.3 )	( 16.74 )	0.24 ~ 0.5	12	11,680	<b>SS5-35</b>
S1	1610	174.3	( 164.2 )	( 17.77 )	0.24 ~ 0.5	12	12,740	<b>SS5-36</b>
S1	1726	195.4	( 176 )	( 19.93 )	0.24 ~ 0.5	14	14,480	<b>SS5-38</b>
S2	1536	181.8	( 156.6 )	( 18.54 )	0.24 ~ 0.5	13	15,650	<b>SS5-40</b>
S2	1633	202	( 166.5 )	( 20.6 )	0.28 ~ 0.58	14	17,000	<b>SS5-42</b>
S2	1731	223.3	( 176.5 )	( 22.77 )	0.28 ~ 0.58	15	18,780	<b>SS5-44</b>
S2	1780	234.4	( 181.5 )	( 23.9 )	0.28 ~ 0.58	16	18,920	<b>SS5-45</b>
S2	1829	245.8	( 186.5 )	( 25.06 )	0.28 ~ 0.58	16	20,360	<b>SS5-46</b>
S2	1927	269.3	( 196.5 )	( 27.46 )	0.28 ~ 0.58	17	22,290	<b>SS5-48</b>
S4	2026	294	( 206.6 )	( 29.98 )	0.28 ~ 0.58	15	23,640	<b>SS5-50</b>
S2	2125	319.9	( 216.7 )	( 32.62 )	0.28 ~ 0.58	18	26,050	<b>SS5-52</b>
S2	2224	347	( 226.8 )	( 35.38 )	0.28 ~ 0.58	19	28,060	<b>SS5-54</b>
S2	2274	360.9	( 231.9 )	( 36.8 )	0.28 ~ 0.58	20	28,190	<b>SS5-55</b>
S2	2324	375.1	( 237 )	( 38.25 )	0.28 ~ 0.58	21	30,180	<b>SS5-56</b>
S2	2423	404.5	( 247.1 )	( 41.25 )	0.28 ~ 0.58	22	32,640	<b>SS5-58</b>
S4	2523	435	( 257.3 )	( 44.36 )	0.28 ~ 0.58	23	37,200	<b>SS5-60</b>

【注1】表記の許容トルクは任意の使用条件で計算した参考値です。詳細については27頁をご参照ください。

【注2】バックラッシは同一型番どうし理論値で組立てたときの数値です。



# SS平歯車 モジュール 6 ~ 10

平歯車  
SS

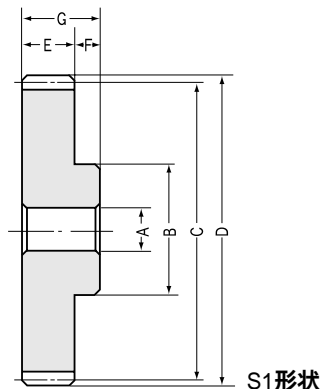

## モジュール 6

カタログ記号	モジュール	歯数	穴径	ボス径	基準円直径	歯先円直径	歯幅	ボス長さ	全長	ウェブ厚	リム径
	<i>m</i>	<i>z</i>	AH7	B	C	D	E	F	G	H	I
SS6-12	6	12	25	55	72	84	60	28	88		
SS6-13	6	13	25	58	78	90	60	28	88		
SS6-14	6	14	25	60	84	96	60	28	88		
SS6-15	6	15	25	70	90	102	60	28	88		
SS6-16	6	16	25	75	96	108	60	28	88		
SS6-17	6	17	25	78	102	114	60	28	88		
SS6-18	6	18	25	80	108	120	60	28	88		
SS6-19	6	19	25	90	114	126	60	28	88		
SS6-20	6	20	25	100	120	132	60	28	88		
SS6-21	6	21	28	105	126	138	60	28	88		
SS6-22	6	22	28	110	132	144	60	28	88		
SS6-23	6	23	28	115	138	150	60	28	88		
SS6-24	6	24	28	120	144	156	60	28	88		
SS6-25	6	25	28	125	150	162	60	28	88		
SS6-26	6	26	28	130	156	168	60	28	88		
SS6-27	6	27	28	135	162	174	60	28	88		
SS6-28	6	28	28	140	168	180	60	28	88		
SS6-30	6	30	30	150	180	192	60	28	88		
SS6-32	6	32	30	150	192	204	60	23	83		
SS6-34	6	34	30	150	204	216	60	23	83		
SS6-35	6	35	30	150	210	222	60	23	83		
SS6-36	6	36	30	150	216	228	60	23	83		
SS6-38	6	38	30	150	228	240	60	23	83		
SS6-40	6	40	30	150	240	252	60	23	83		
SS6-42	6	42	40	150	252	264	60	23	83		
SS6-44	6	44	40	150	264	276	60	23	83		
SS6-45	6	45	40	180	270	282	60	23	83		
SS6-46	6	46	40	180	276	288	60	23	83		
SS6-48	6	48	40	180	288	300	60	23	83		
SS6-50	6	50	40	180	300	312	60	23	83		

## モジュール 8

SS8-12	8	12	28	75	96	112	75	35	110		
SS8-13	8	13	28	80	104	120	75	35	110		
SS8-14	8	14	28	85	112	128	75	35	110		
SS8-15	8	15	28	90	120	136	75	35	110		
SS8-16	8	16	28	100	128	144	75	35	110		
SS8-17	8	17	28	105	136	152	75	35	110		
SS8-18	8	18	28	110	144	160	75	35	110		
SS8-19	8	19	28	120	152	168	75	35	110		
SS8-20	8	20	28	130	160	176	75	35	110		
SS8-21	8	21	30	140	168	184	75	35	110		
SS8-22	8	22	30	150	176	192	75	35	110		
SS8-23	8	23	30	155	184	200	75	35	110		
SS8-24	8	24	30	160	192	208	75	35	110		
SS8-25	8	25	30	170	200	216	75	35	110		
SS8-26	8	26	30	170	208	224	75	35	110		
SS8-27	8	27	30	170	216	232	75	35	110		
SS8-28	8	28	30	180	224	240	75	35	110		
SS8-30	8	30	30	180	240	256	75	35	110		

## モジュール 10

SS10-15	10	15	30	115	150	170	90	40	130		
SS10-20	10	20	30	165	200	220	90	40	130		
SS10-25	10	25	40	200	250	270	90	40	130		



## 共通仕様

精度等級	JIS N8級 (JIS B 1702-1:1998) 旧JIS 4級 (JIS B 1702:1976)	歯面硬度	194HB以下
歯形	並歯	表面処理	黒染
圧力角	20°	歯面仕上げ	切削
材料	S45C	歯切基準面	穴
熱処理		追加工	可能

形状	許容トルク(N・m) 注1		許容トルク(kgf・m)		バックラッシュ (mm) 注2	質量 (kg)	価格 (円)	カタログ記号
	曲げ強さ	歯面強さ	曲げ強さ	歯面強さ				
S1	549.7	26.76	( 56.05 )	( 2.729 )	0.22 ~ 0.48	2	4,490	<b>SS6-12</b>
S1	630.6	32.42	( 64.3 )	( 3.306 )	0.22 ~ 0.48	2.5	4,880	<b>SS6-13</b>
S1	713.4	38.39	( 72.75 )	( 3.915 )	0.22 ~ 0.48	2.8	5,210	<b>SS6-14</b>
S1	798.1	44.91	( 81.38 )	( 4.58 )	0.22 ~ 0.48	3.4	5,880	<b>SS6-15</b>
S1	884.2	51.96	( 90.16 )	( 5.299 )	0.22 ~ 0.48	3.9	6,520	<b>SS6-16</b>
S1	971.7	59.56	( 99.09 )	( 6.073 )	0.22 ~ 0.48	4.4	6,600	<b>SS6-17</b>
S1	1060	67.68	( 108.1 )	( 6.902 )	0.22 ~ 0.48	5	7,270	<b>SS6-18</b>
S1	1150	76.4	( 117.3 )	( 7.791 )	0.22 ~ 0.48	5.8	7,410	<b>SS6-19</b>
S1	1242	85.85	( 126.6 )	( 8.754 )	0.22 ~ 0.48	6.5	8,170	<b>SS6-20</b>
S1	1333	95.88	( 135.9 )	( 9.777 )	0.26 ~ 0.56	7.5	9,040	<b>SS6-21</b>
S1	1426	106.5	( 145.4 )	( 10.86 )	0.26 ~ 0.56	8.1	9,180	<b>SS6-22</b>
S1	1519	117.7	( 154.9 )	( 12 )	0.26 ~ 0.56	8.9	10,160	<b>SS6-23</b>
S1	1613	129.4	( 164.5 )	( 13.2 )	0.26 ~ 0.56	9.8	10,360	<b>SS6-24</b>
S1	1708	141.8	( 174.2 )	( 14.46 )	0.26 ~ 0.56	10.5	11,230	<b>SS6-25</b>
S1	1803	154.3	( 183.9 )	( 15.73 )	0.26 ~ 0.56	11.4	12,200	<b>SS6-26</b>
S1	1900	167.1	( 193.7 )	( 17.04 )	0.26 ~ 0.56	12.1	12,390	<b>SS6-27</b>
S1	1996	180.6	( 203.5 )	( 18.42 )	0.26 ~ 0.56	12.7	13,870	<b>SS6-28</b>
S1	2191	209.2	( 223.4 )	( 21.33 )	0.26 ~ 0.56	15.1	15,720	<b>SS6-30</b>
S1	1989	199.9	( 202.8 )	( 20.38 )	0.26 ~ 0.56	18	17,470	<b>SS6-32</b>
S1	2154	227.7	( 219.6 )	( 23.22 )	0.26 ~ 0.56	19	19,180	<b>SS6-34</b>
S1	2236	242.4	( 228 )	( 24.72 )	0.26 ~ 0.56	19	24,030	<b>SS6-35</b>
S1	2319	257.6	( 236.5 )	( 26.27 )	0.26 ~ 0.56	22	24,550	<b>SS6-36</b>
S1	2486	289.4	( 253.5 )	( 29.51 )	0.26 ~ 0.56	23	25,350	<b>SS6-38</b>
S1	2654	323.1	( 270.6 )	( 32.95 )	0.26 ~ 0.56	24	29,400	<b>SS6-40</b>
S1	2821	358.9	( 287.7 )	( 36.6 )	0.3 ~ 0.64	27	30,940	<b>SS6-42</b>
S1	2990	396.7	( 304.9 )	( 40.45 )	0.3 ~ 0.64	30	33,060	<b>SS6-44</b>
S1	3075	416.3	( 313.6 )	( 42.45 )	0.3 ~ 0.64	31	34,790	<b>SS6-45</b>
S1	3160	436.4	( 322.2 )	( 44.5 )	0.3 ~ 0.64	34	36,620	<b>SS6-46</b>
S1	3330	478.3	( 339.6 )	( 48.77 )	0.3 ~ 0.64	35	38,260	<b>SS6-48</b>
S1	3501	522	( 357 )	( 53.23 )	0.3 ~ 0.64	37	40,090	<b>SS6-50</b>

S1	1222	62.63	( 124.6 )	( 6.387 )	0.28 ~ 0.58	4.8	8,770	<b>SS8-12</b>
S1	1401	75.16	( 142.9 )	( 7.664 )	0.28 ~ 0.58	4.8	10,040	<b>SS8-13</b>
S1	1586	88.89	( 161.7 )	( 9.064 )	0.28 ~ 0.58	6.6	11,040	<b>SS8-14</b>
S1	1773	104.1	( 180.8 )	( 10.62 )	0.28 ~ 0.58	7.6	11,310	<b>SS8-15</b>
S1	1965	120.7	( 200.4 )	( 12.31 )	0.28 ~ 0.58	8.9	12,460	<b>SS8-16</b>
S1	2159	138.6	( 220.2 )	( 14.13 )	0.28 ~ 0.58	10	13,860	<b>SS8-17</b>
S1	2357	157.8	( 240.3 )	( 16.09 )	0.28 ~ 0.58	12	15,340	<b>SS8-18</b>
S1	2557	178.2	( 260.7 )	( 18.17 )	0.28 ~ 0.58	13	16,820	<b>SS8-19</b>
S1	2759	200.1	( 281.3 )	( 20.4 )	0.28 ~ 0.58	15	17,180	<b>SS8-20</b>
S1	2963	223.2	( 302.1 )	( 22.76 )	0.32 ~ 0.66	17	18,560	<b>SS8-21</b>
S1	3168	247.6	( 323.1 )	( 25.25 )	0.32 ~ 0.66	19	20,090	<b>SS8-22</b>
S1	3376	273.4	( 344.3 )	( 27.88 )	0.32 ~ 0.66	20	22,640	<b>SS8-23</b>
S1	2988	249.9	( 304.7 )	( 25.48 )	0.32 ~ 0.66	22	24,650	<b>SS8-24</b>
S1	3164	272.8	( 322.6 )	( 27.82 )	0.32 ~ 0.66	24	25,010	<b>SS8-25</b>
S1	3340	296.8	( 340.6 )	( 30.27 )	0.32 ~ 0.66	28	27,250	<b>SS8-26</b>
S1	3518	321.9	( 358.7 )	( 32.83 )	0.32 ~ 0.66	30	29,580	<b>SS8-27</b>
S1	3696	348.2	( 376.9 )	( 35.51 )	0.32 ~ 0.66	33	32,030	<b>SS8-28</b>
S1	4056	403.9	( 413.6 )	( 41.19 )	0.32 ~ 0.66	36	36,500	<b>SS8-30</b>

S1	3325	202.6	( 339.1 )	( 20.66 )	0.34 ~ 0.68	15	21,020	<b>SS10-15</b>
S1	4310	323.3	( 439.5 )	( 32.97 )	0.34 ~ 0.68	28.2	32,650	<b>SS10-20</b>
S1	5931	529.3	( 604.8 )	( 53.97 )	0.36 ~ 0.76	43.3	45,690	<b>SS10-25</b>

【注1】表記の許容トルクは任意の使用条件で計算した参考値です。詳細については27頁をご参照ください。

【注2】バックラッシュは同一型番どうし理論値で組立てたときの数値です。