

# 平面ラッチ

# ステンレス製 C-1101

FLUSH LATCHES



### 特徴 Feature

- C-1101-2は、ラッチを加工して使用できます。
- ステンレス製で耐食性に優れています。
- C-1101-2 can be used after machining latch.
- Corrosion-resistant stainless steel is used.

仕様 ●材質：本体/冷間圧延ステンレス鋼板 (SUS304)  
ラッチ部/快削黄銅引抜棒 (BsBD2)

- 用途 ●表面仕上：ヘアライン仕上  
●航空機(キッチン)・屋外用分電盤  
納期 ●標準品・・・即納します

Specifications ●Material: Main body: Cold rolled stainless steel plate (SUS304)  
Latch: Free-cutting brass drawn bar (BsBD2)

- Specific use ●Finish: Hairline finish  
●Aircraft (kitchens) and outdoor distribution boards

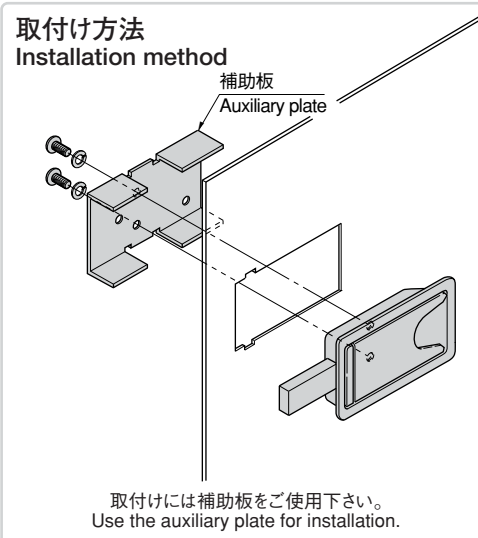
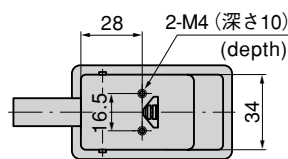
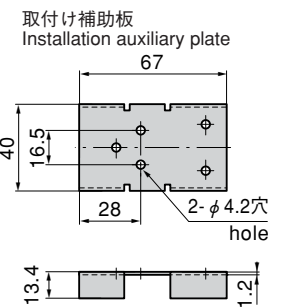
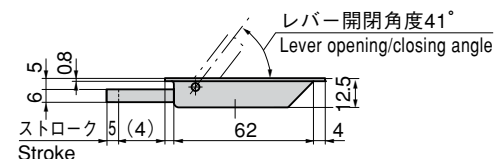
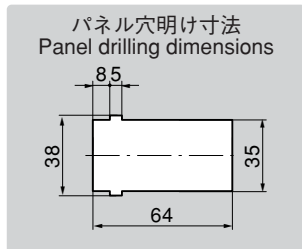
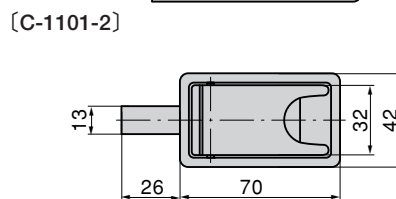
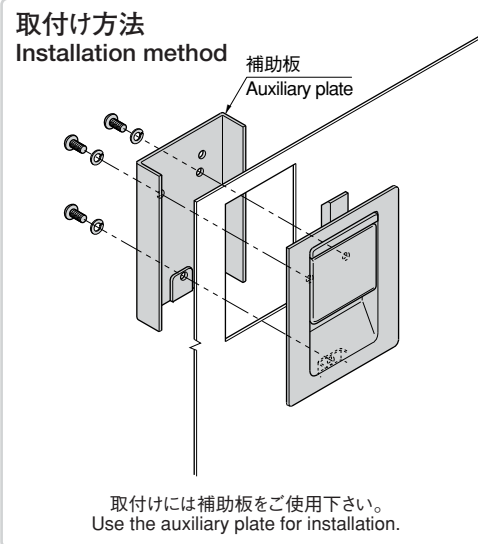
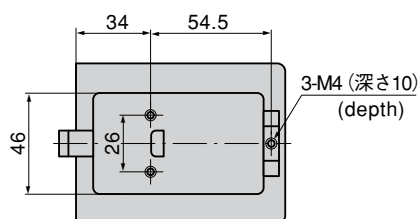
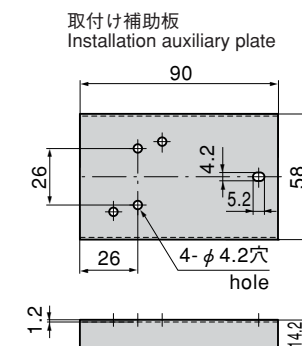
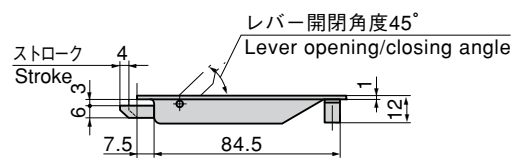
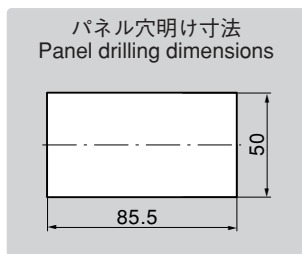
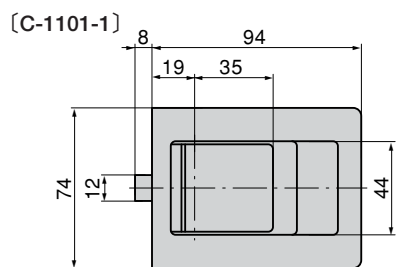

小松川 E-mail : komatugawa@takigen.co.jp  
八王子 E-mail : hachiouji@takigen.co.jp  
川崎 E-mail : kawasaki@takigen.co.jp

厚木 E-mail : atsugi@takigen.co.jp  
沼津 E-mail : numazu@takigen.co.jp  
京都 E-mail : kyoto@takigen.co.jp

広島 E-mail : hirosima@takigen.co.jp  
福岡 E-mail : fukuoka@takigen.co.jp  
韓国 E-mail : kang@takigen.co.kr