

ロータリーロック

ステンレス製 C-1879

ROTARY LOCKS

PAT.PEND.

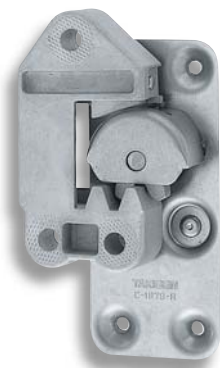

C-1879-R

特徴 Feature

- 受金具が頑丈な耐振構造です。
- 振動・衝撃の激しい大型扉に最適です。
- 右用・左用(本図・写真共右用です。)
- The striker is rigid vibration-proof.
- Suitable for the large doors subject to excessive vibration and impact.
- For right-hand or left-hand use. (The photos and drawings show the right-hand use)

仕様 ● 材質：本体/ステンレス鋼板(SUS304)
受金具/ステンレス鋼铸件(SUS304)

- 表面仕上：酸洗処理
- 付属品：受金具

用途 ● 特装车・建設機械・船舶
納期 ● 標準品・・・即納します

Specifications ● Material: Main unit: Stainless steel plate (SUS304)
Striker: Cast stainless steel (SUS304)

- Finish: Acid cleaning
- Accessories: Striker

Specific use ● Specially equipped vehicles, construction machinery, ships

商品番号 Product No.	RoHS	CAD	製品質量(g) Mass	コード Code	単価 Price	箱入数 Quantity per box
C-1879-L	●	●	700	22046	¥7,600	20
C-1879-R	●	●	700	22047	¥7,600	

● : RoHS指令対応品 ▲ : RoHS指令に対応可能です。お問合せ下さい。 ※箱単位はご相談下さい。

〔ロック本体
Lock main unit〕

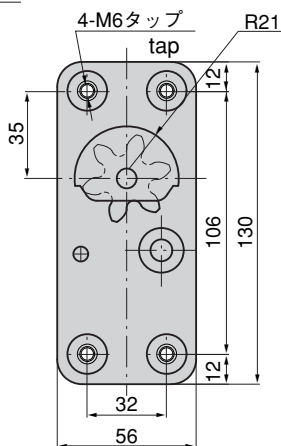
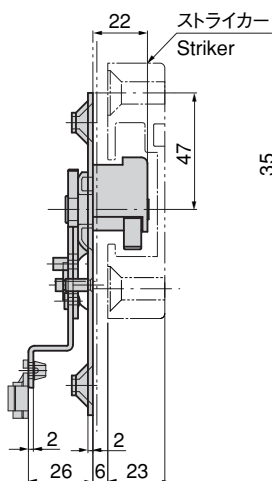
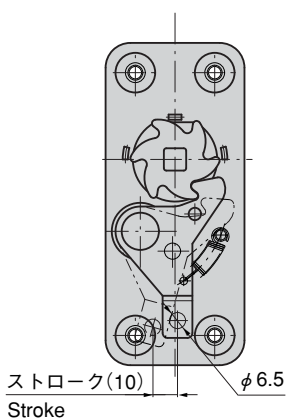

〔受金具
Striker〕

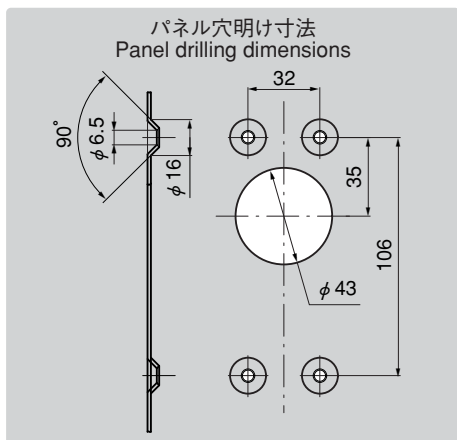
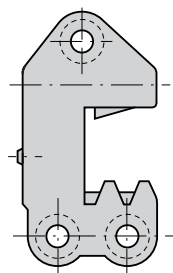
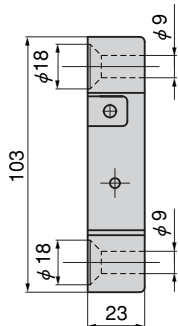
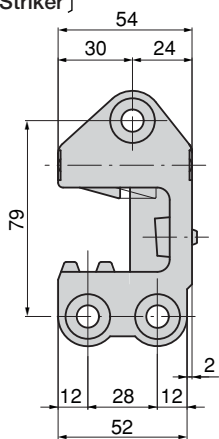

建設機械のロック装置に最適です。
Suitable for the lock mechanism of
construction machinery.

使用例 Example of application

