

# 化粧ビス・座金



ステンレス製 **C-1029**

黄銅製 **C-29**

SCREWS / WASHERS

ファスナー  
ラッチ錠  
ドアキャッチ  
スナッチロック  
コントロールセンター  
工業用錠前  
周辺機器(C)  
フリーザー金具



C-1029-6×25



C-1029-3×15

〔化粧ビス〕  
Dressing screw

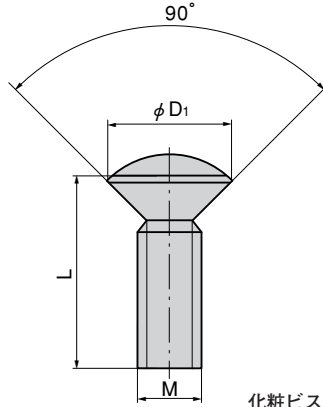
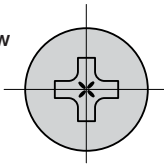

C-29-6×25



C-29-3×15

〔化粧ビス〕

- 仕様 ●材質：C-1029/ステンレス鋼棒(SUS304)  
C-29/快削黄銅棒(C3602BD)  
●表面仕上：C-29/クロムめっき(MBCr)  
納期 ●標準品・・・即納します

〔Dressing screw〕

- Specifications ●Material: C-1029: Stainless steel bar (SUS304)  
C-29: Free cutting brass bar (C3602BD)  
●Finish: Chrome plating (MBCr)

〔化粧座金〕

- 仕様 ●材質：C-1029-S/ステンレス焼結(SUS304L)  
C-1029/冷間圧延ステンレス鋼板(SUS304)  
●表面仕上：C-1029-S/光沢バレル研磨  
納期 ●標準品・・・即納します

〔Dressing washer〕

- Specifications ●Material: C-1029-S: Stainless steel sintered (SUS304L)  
C-1029: Cold rolled stainless steel plate (SUS304)  
●Finish: Gloss barrel buffing



C-1029-M6



C-1029-M3



C-1029-S-M6



C-1029-S-M3

〔化粧座金〕  
Dressing washer

〔C-1029-M□用〕  
(プレス製)  
Press

〔C-1029-S-M□用〕  
(焼結製)  
Sintered

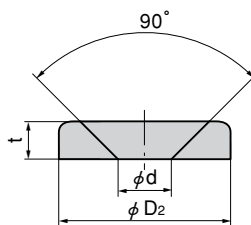
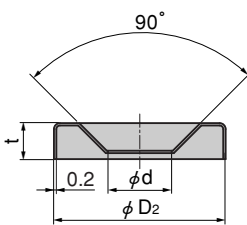
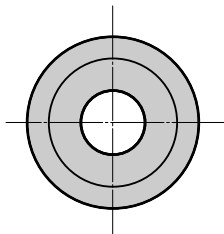
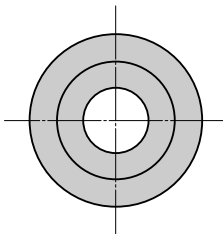

化粧ビス Dressing screw

(ISO)

商品番号 Product No.		RoHS		φD <sub>1</sub>	製品質量(g) Mass	コード Code		価格 Price		箱入数 Quantity per box
SUS	黄銅 Brass	SUS	黄銅 Brass			SUS304	BS	SUS304	BS	
C-1029-3×10	C-29-3×10	●	●	6	1	20803	20121	¥30/10ヶ	¥50/10ヶ	8000
C-1029-3×15	C-29-3×15	●	●		1	20804	20122	¥40/10ヶ	¥60/10ヶ	5000
C-1029-3×20	C-29-3×20	●	●		1.5	20805	20123	¥40/10ヶ	¥70/10ヶ	4000
C-1029-3×25	C-29-3×25	●	●		1.5	20806	20124	¥50/10ヶ	¥90/10ヶ	3000
C-1029-4×10	C-29-4×10	●	●	8	1.5	20807	20125	¥50/10ヶ	¥70/10ヶ	4000
C-1029-4×15	C-29-4×15	●	●		2	20808	20126	¥60/10ヶ	¥90/10ヶ	3000
C-1029-4×20	C-29-4×20	●	●		2.5	20809	20127	¥70/10ヶ	¥110/10ヶ	2500
C-1029-4×25	C-29-4×25	●	●	10	2.5	20810	20128	¥80/10ヶ	¥130/10ヶ	2000
C-1029-5×10	C-29-5×10	●	●		3	20811	20129	¥80/10ヶ	¥110/10ヶ	3000
C-1029-5×15	C-29-5×15	●	●	10	3.5	20812	20130	¥90/10ヶ	¥140/10ヶ	2000
C-1029-5×20	C-29-5×20	●	●		3.5	20813	20131	¥100/10ヶ	¥160/10ヶ	1500
C-1029-5×25	C-29-5×25	●	●	12	4.5	20814	20132	¥120/10ヶ	¥200/10ヶ	1200
C-1029-6×10	C-29-6×10	●	●		3	20815	20133	¥110/10ヶ	¥170/10ヶ	2000
C-1029-6×15	C-29-6×15	●	●	12	4.5	20816	20134	¥120/10ヶ	¥210/10ヶ	1500
C-1029-6×20	C-29-6×20	●	●		5	20817	20135	¥140/10ヶ	¥250/10ヶ	1200
C-1029-6×25	C-29-6×25	●	●	16	6	20818	20136	¥180/10ヶ	¥270/10ヶ	1000
C-1029-8×10	C-29-8×10	●	●		7.5	20819	20137	¥41/1ヶ	¥60/1ヶ	1000
C-1029-8×15	C-29-8×15	●	●	16	10	20820	20138	¥44/1ヶ	¥70/1ヶ	800
C-1029-8×20	C-29-8×20	●	●		11	20821	20139	¥45/1ヶ	¥70/1ヶ	600
C-1029-8×25	C-29-8×25	●	●		15	20822	20140	¥46/1ヶ	¥80/1ヶ	450

化粧座金(プレス製) Dressing washer (Press)

商品番号 Product No.	RoHS	φD <sub>2</sub>	φd	t	製品質量(g) Mass	コード Code	価格 Price	箱入数 Quantity per box
C-1029-M3用	●	9.5	3.3	2.2	35/100個	20823	¥50/10ヶ	8000
C-1029-M4用	●	11.5	4.3	2.3	25/100個	20824	¥70/10ヶ	4000
C-1029-M5用	●	14.3	5.3	3	40/100個	20825	¥90/10ヶ	2500
C-1029-M6用	●	16	6.3	3.2	55/100個	20826	¥120/10ヶ	2000

化粧座金(焼結製) Dressing washer (Sintered)

商品番号 Product No.	RoHS	CAD	φD <sub>2</sub>	φd	t	製品質量(g) Mass	コード Code	単価 Price	箱入数 Quantity per box
C-1029-S-M3	●	●	10	3.5	2	0.8	22140	¥30	10000
C-1029-S-M4	●	●	12	4.5	2.5	1.3	22141	¥36	5000
C-1029-S-M5	●	●	14	6	3	2	22142	¥50	3000
C-1029-S-M6	●	●	16	7	3.5	3	22143	¥65	2500
C-1029-S-M8	●	●	22	9	5	8	22144	¥85	2000

●：RoHS指令対応品 ▲：RoHS指令に対応可能です。お問合せ下さい。 ※箱単位はご相談下さい。

即日配達 of タキゲン 全国直販店

東京 ☎(03)3492-2001 Fax.(03)3492-3001  
大阪 ☎(06)6933-8001 Fax.(06)6933-8000

名古屋 ☎(0568)75-5001 Fax.(0568)77-2200

札幌 ☎(011)846-2001 Fax.(011)846-0900  
仙台 ☎(022)235-2101 Fax.(022)283-0110

新潟 ☎(025)274-2500 Fax.(025)274-5700

宇都宮 ☎(028)627-8001 Fax.(028)627-8000  
浦和 ☎(048)855-3111 Fax.(048)855-8705