

# コントロール キースイッチ ダブルピン

# S-17

CONTROL KEYSWITCHES BITS CYLINDER

C.S.A.登録品 No.: LR65938-3M  
U.L.登録品 No.: E106043

### 特徴 Feature

- 特殊12枚タンブラー構成により、鍵違いは200種類できます(ガイドプレート交換で鍵違いは増設)。
- パネル穴明けはS-8と同寸法です。
- Special 12-tumbler structure. Key differences: 200 sets. (key differences increased with guide place replaced)
- Panel drilling dimensions are same as S-8.



S-17-90-B

キーNo.K710  
Key

- 仕様**
- 材 質: 亜鉛合金 (ZDC)
  - 表面仕上: ステンレスカバー
  - 同一鍵番号・鍵違いがあります。
- 用途**
- 各種電源スイッチ
- 納期**
- 標準品・・・即納します
- スイッチ部**
- 定 格: AC 125V・3A (抵抗負荷)  
DC30V・3A (抵抗負荷)
- 特性**
- 接触抵抗: 20mΩ以下
  - 絶縁抵抗: 100MΩ以上 (DC500Vメガ)
  - 耐電圧: (50/60Hz、1分間)  
非連続端子間 AC1000V  
各端子と非充電金属部間 AC1500V
  - 耐久性: 1万5000回以上
  - 切替接点: 1回路2接点型・2回路2接点型
  - 接点材料: 銀めっき
  - 絶縁材料: DAP樹脂 (UL94-HB)
  - 使用周囲温度: -20~+70℃ (氷結しないこと)
  - 使用周囲湿度: 85%RH以下
  - 耐振動: 10~55Hz 複振幅1.5mm
  - 耐衝撃: 約30G以上
- 備考**
- U.L.・C.S.A.認定品は受注生産です。

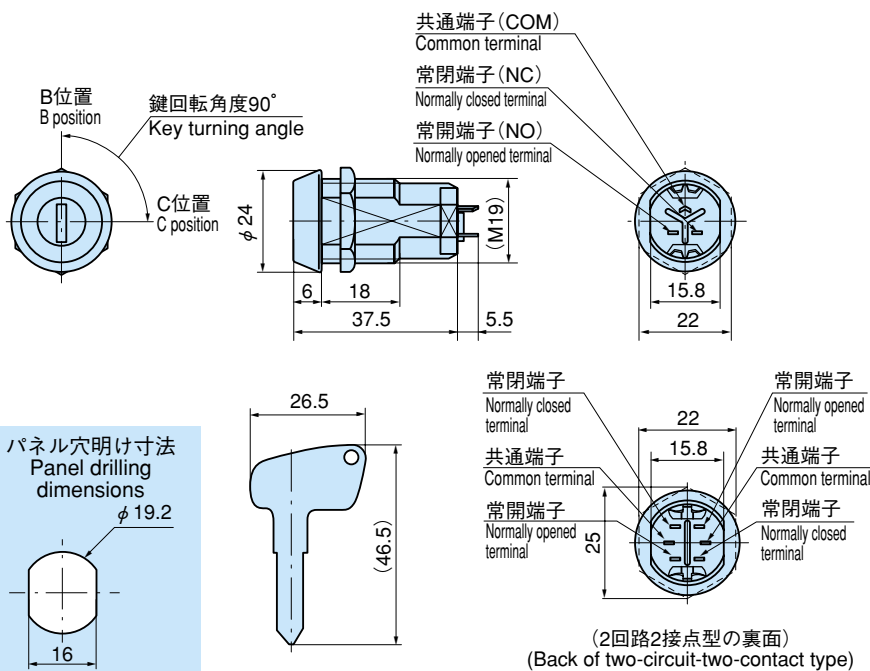

●印の位置は鍵が抜き差しできます。  
Position of mark (●) shows that key can be inserted/removed.

接点構成表 Contact structures table

商品番号 Product No.	鍵回転角度 Key turning angle	B位置 B position	C位置 C position
S-17-90-B-1同番 Keyed alike (1回路2接点型) (one-circuit-two-contact type)	90° B位置 C位置	● SW COM NO NC	● SW COM NO NC
S-17-90-B-1鍵違い Key differences (1回路2接点型) (one-circuit-two-contact type)	90° B位置 C位置	● SW COM NO NC	● SW COM NO NC
S-17-90-BC-1同番 Keyed alike (1回路2接点型) (one-circuit-two-contact type)	90° B位置 C位置	● SW COM NO NC	● SW COM NO NC
S-17-90-BC-1鍵違い Key differences (1回路2接点型) (one-circuit-two-contact type)	90° B位置 C位置	● SW COM NO NC	● SW COM NO NC
S-17-90-B-2同番 Keyed alike (2回路2接点型) (two-circuit-two-contact type)	90° B位置 C位置	● SW <sub>1</sub> COM NO NC SW <sub>2</sub> COM NO NC	● SW <sub>1</sub> COM NO NC SW <sub>2</sub> COM NO NC
S-17-90-B-2鍵違い Key differences (2回路2接点型) (two-circuit-two-contact type)	90° B位置 C位置	● SW <sub>1</sub> COM NO NC SW <sub>2</sub> COM NO NC	● SW <sub>1</sub> COM NO NC SW <sub>2</sub> COM NO NC
S-17-90-BC-2同番 Keyed alike (2回路2接点型) (two-circuit-two-contact type)	90° B位置 C位置	● SW <sub>1</sub> COM NO NC SW <sub>2</sub> COM NO NC	● SW <sub>1</sub> COM NO NC SW <sub>2</sub> COM NO NC
S-17-90-BC-2鍵違い Key differences (2回路2接点型) (two-circuit-two-contact type)	90° B位置 C位置	● SW <sub>1</sub> COM NO NC SW <sub>2</sub> COM NO NC	● SW <sub>1</sub> COM NO NC SW <sub>2</sub> COM NO NC

- Specifications**
- Material: Zinc alloy (ZDC)
  - Finish: Stainless cover
  - Keyed alike and key differences are available.
- Specific use**
- Various power switches
- Switch characteristic**
- Rated: AC 125V 3A (resistance load)/  
DC 30V 3A (resistance load)
  - Contact resistance: 20mΩ or less
  - Insulation resistance: 100MΩ or more  
(DC 500V mega)
  - Withstand voltage: (50/60 Hz, one minute)  
Between non-continuous terminals: AC1000V  
Between each terminal and non-charged metal: AC1500V
  - Durability: 15,000 time or more
  - Switch contact: One-circuit-two-contact/Two-circuit-two-contact
  - Contact material: Silver plating
  - Insulation material: DAP resin (UL94-HB)
  - Ambient temperature: -20°C to +70°C (non-condensing)
  - Ambient humidity: 85%RH or less
  - Vibration resistance: 10 to 55Hz multiple-amplitude 1.5mm
  - Impact resistance: Approx. 30G or more
- Remarks**
- UL and CSA approved are custom-made.

商品番号 Product No.	製品質量 (g) Mass	コード Code	価格 Price	箱入数 Quantity per box
S-17-90-B-1同番 Keyed alike	60	40148	¥ 1,790	50
S-17-90-B-1鍵違い Key differences	60	40149	¥ 1,890	
S-17-90-B-2同番 Keyed alike	60	40207	¥ 1,850	
S-17-90-B-2鍵違い Key differences	60	40208	¥ 1,950	
S-17-90-BC-1同番 Keyed alike	60	40150	¥ 1,790	
S-17-90-BC-1鍵違い Key differences	60	40151	¥ 1,890	
S-17-90-BC-2同番 Keyed alike	60	40209	¥ 1,850	
S-17-90-BC-2鍵違い Key differences	60	40210	¥ 1,950	